

**TM-L90**

**TM-L90 Peeler Model**

**Technical Reference Guide**



### **Cautions**

- ❑ No part of this document may be reproduced, stored in a retrieval system, or transmitted in any form or by any means, electronic, mechanical, photocopying, recording, or otherwise, without the prior written permission of Seiko Epson Corporation.
- ❑ The contents of this document are subject to change without notice. Please contact us for the latest information.
- ❑ While every precaution has been taken in the preparation of this document, Seiko Epson Corporation assumes no responsibility for errors or omissions.
- ❑ Neither is any liability assumed for damages resulting from the use of the information contained herein.
- ❑ Neither Seiko Epson Corporation nor its affiliates shall be liable to the purchaser of this product or third parties for damages, losses, costs, or expenses incurred by the purchaser or third parties as a result of: accident, misuse, or abuse of this product or unauthorized modifications, repairs, or alterations to this product, or (excluding the U.S.) failure to strictly comply with Seiko Epson Corporation's operating and maintenance instructions.
- ❑ Seiko Epson Corporation shall not be liable against any damages or problems arising from the use of any options or any consumable products other than those designated as Original Epson Products or Epson Approved Products by Seiko Epson Corporation.

### **Trademarks**

Microsoft and Windows are registered trademarks of Microsoft Corporation.

QR Code is a registered trademark of DENSO WAVE INCORPORATED in Japan and other countries.

All other trademarks are the property of their respective owners and used for identification purpose only.

### **ESC/POS Command System**

Epson ESC/POS is a proprietary POS printer command system that includes patented or patent-pending commands. ESC/POS is compatible with most Epson POS printers and displays.

ESC/POS is designed to reduce the processing load on the host computer in POS environments. It comprises a set of highly functional and efficient commands and also offers the flexibility to easily make future upgrades.

©Seiko Epson Corporation 2002–2025

---

## **For Safety**

### **Key to Symbols**

The symbols in this manual are identified by their level of importance, as defined below. Read the following carefully before handling the product.



#### **WARNING:**

*You must follow warnings carefully to avoid serious bodily injury.*



#### **CAUTION:**

*Provides information that must be observed to prevent damage to the equipment or loss of data.*

- Possibility of sustaining physical injuries.*
- Possibility of causing physical damage.*
- Possibility of causing information loss.*



#### **Note:**

*Provides important information and useful tips on handling the equipment.*

## Warnings

### **WARNING:**

- ❑ *Shut down your equipment immediately if it produces smoke, a strange odor, or unusual noise. Continued use may lead to fire or electric shock. Immediately unplug the equipment.*
- ❑ *Only disassemble this product as described in this manual. Do not make modifications to the unit. Tampering with this product may result in injury, fire, or electric shock.*
- ❑ *Do not install this product or handle cables during a thunderstorm in order to avoid risk of electric shock.*
- ❑ *Be sure to use the specified power source. Connection to an improper power source may cause fire or shock.*
- ❑ *Never insert or disconnect the power plug with wet hands. Doing so may result in severe shock.*
- ❑ *Do not allow foreign matter to fall into the equipment. Penetration by foreign objects may lead to fire or electric shock.*
- ❑ *If water or other liquid spills into this equipment, turn off the power switch and unplug the power cord immediately. Continued usage may lead to fire or electric shock.*
- ❑ *Do not place multiple loads on power outlet. Overloading the outlet may lead to fire. Always supply power directly from a standard domestic power outlet.*
- ❑ *Handle the power cord with care. Improper handling may lead to fire or electric shock.*
  - *Do not modify or attempt to repair the cord.*
  - *Do not place any heavy object on top of the cord.*
  - *Avoid excessive bending, twisting, and pulling.*
  - *Do not place the cord near heating equipment.*
  - *Check that the plug is clean before plugging it in.*
  - *Be sure to push the plug all the way in.*

## Cautions

### **CAUTION:**

- ❑ *Do not connect cables in ways other than those mentioned in this manual. Different connections may cause equipment damage and burning.*
- ❑ *Be sure to set this equipment on a firm, stable horizontal surface. Product may break or cause injury if it falls.*
- ❑ *Do not use in locations subject to high humidity or dust levels. Excessive humidity and dust may cause equipment damage, fire, or shock.*
- ❑ *Do not place heavy objects on top of this equipment. Never stand or lean on this equipment. Equipment may fall or collapse, causing breakage and possible injury.*
- ❑ *To ensure safety, unplug this equipment prior to leaving it unused for an extended period.*
- ❑ *Take care not to injure your fingers on the manual cutter*
  - *When you remove printed paper*
  - *When you perform other operations such as loading/replacing roll paper*
- ❑ *Do not open the roll paper cover without taking the necessary precautions, as this can result in injury from the autocutter fixed blade.*
- ❑ *Do not use aerosol sprayers containing flammable gas inside or around this product. Doing so may cause fire.*
- ❑ *Make sure to avoid bumping or otherwise exposing the printer to strong impact during operation.*
- ❑ *If this product is used in a place where silicon-based gases including siloxane (silicon adhesive, silicon oil, silicon powder, etc.) or malignant gases (nitric acid, hydrogen sulfide, ammonia, chlorine, etc.) are present in the air, contact failure may occur in mechanical contacts such as mechanical switch or DC motor in a short time due to adhesion or oxidation of the insulation film.*

---

## **Restriction of Use**

When this product is used for applications requiring high reliability/safety such as transportation devices related to aviation, rail, marine, automotive etc.; disaster prevention devices; various safety devices etc; or functional/precision devices etc, you should use this product only after giving consideration to including fail-safes and redundancies into your design to maintain safety and total system reliability. Because this product was not intended for use in applications requiring extremely high reliability/safety such as aerospace equipment, main communication equipment, nuclear power control equipment, or medical equipment related to direct medical care etc, please make your own judgment on this product's suitability after a full evaluation.

---

## **Modular Connector**

Use the modular connectors specifically designed for the cash drawer for this product. Do not connect these connectors to an ordinary telephone line.

## **About This Manual**

### **Aim of the Manual**

This manual was created to provide all information necessary for system planning, design, installations and application of the printer for designers and developers of POS systems.

### **Manual Content**

The manual is made up of the following sections:

|           |                                                                                        |
|-----------|----------------------------------------------------------------------------------------|
| Chapter 1 | Product Overview                                                                       |
| Chapter 2 | Setup                                                                                  |
| Chapter 3 | Connecting to the Host Computer and Options                                            |
| Chapter 4 | Setting/Checking Modes                                                                 |
| Chapter 5 | Application Development Information                                                    |
| Chapter 6 | ESC/POS Command-Related Information                                                    |
| Chapter 7 | Handling                                                                               |
| Appendix  | Setting items for Memory Switch Setting Mode<br>Specifications<br>Character Code Table |

### **Related Documentation**

The following documents also relate to the TM-L90 / TM-L90 Peeler Model.

| <b>Name of document</b>                                                                                                                                                             | <b>Description</b>                                                                                               |
|-------------------------------------------------------------------------------------------------------------------------------------------------------------------------------------|------------------------------------------------------------------------------------------------------------------|
| TM-L90 User's Manual (for TM-L90)<br>TM-L90 with Peeler User's Manual (for TM-L90 Peeler other than 39* models)<br>TM-L90 Peeler Model User's Manual (for TM-L90 Peeler 39* models) | Comes with the printer.<br>Provides information to enable POS operators to use the printer safely and correctly. |
| ESC/POS Command Reference                                                                                                                                                           | Provides detailed ESC/POS command information.                                                                   |

|                             |   |
|-----------------------------|---|
| For Safety .....            | 4 |
| Key to Symbols .....        | 4 |
| Warnings .....              | 5 |
| Cautions .....              | 6 |
| Restriction of Use .....    | 6 |
| Modular Connector .....     | 6 |
| About This Manual .....     | 7 |
| Aim of the Manual .....     | 7 |
| Manual Content .....        | 7 |
| Related Documentation ..... | 7 |

**Chapter 1 Product Overview**

|                                              |    |
|----------------------------------------------|----|
| Product Structure .....                      | 11 |
| Models .....                                 | 11 |
| Accessories .....                            | 11 |
| Option .....                                 | 12 |
| Name and Description of Each Part .....      | 13 |
| Part Names (TM-L90) .....                    | 13 |
| Part Names (TM-L90 Peeler Model) .....       | 14 |
| Paper FEED button inside the printer .....   | 15 |
| Control Panel .....                          | 15 |
| Power Switch .....                           | 17 |
| Power Switch Cover .....                     | 18 |
| Mode Switch (TM-L90 Peeler Model Only) ..... | 19 |
| Connectors .....                             | 20 |

**Chapter 2 Setup**

|                                                               |    |
|---------------------------------------------------------------|----|
| Setup Flow .....                                              | 21 |
| Installation Procedures .....                                 | 22 |
| Precaution For Installation .....                             | 22 |
| Instructions for Installation .....                           | 23 |
| Adjusting Roll Paper Near-End Detection Position .....        | 25 |
| With TM-L90 .....                                             | 25 |
| With the TM-L90 Peeler Model .....                            | 29 |
| Connecting AC adapter (PS-180/PS-190) .....                   | 33 |
| Attaching AC adapter .....                                    | 33 |
| Caution about AC adapter and Supply Voltage .....             | 34 |
| Autocutter Settings (TM-L90 only) .....                       | 35 |
| Cautions on the Lengths of the Receipts/Labels to Issue ..... | 35 |
| Setting Procedure .....                                       | 36 |
| Setting Roll Paper Width .....                                | 38 |
| DIP Switch Settings .....                                     | 40 |
| Memory Switch Settings .....                                  | 42 |
| Memory switches of TM-L90 .....                               | 43 |
| Memory switches of TM-L90 Peeler Model .....                  | 48 |
| Paper Loading Method .....                                    | 53 |
| With TM-L90 .....                                             | 53 |
| With the TM-L90 Peeler Model .....                            | 54 |
| Setting Paper Layout .....                                    | 57 |
| Clearing Paper Layout Setting .....                           | 62 |

**Chapter 3 Connecting to the Host Computer and Options**

|                                       |    |
|---------------------------------------|----|
| Connecting the Cable .....            | 63 |
| Connecting to the Host Computer ..... | 64 |
| With the RS-232C Interface .....      | 64 |

|                                                                        |    |
|------------------------------------------------------------------------|----|
| With the Parallel (IEEE1284) Interface .....                           | 67 |
| With the USB Interface .....                                           | 68 |
| With the Ethernet Interface (TM-L90 only) .....                        | 70 |
| With the Wireless LAN Interface .....                                  | 71 |
| Connecting the Cash Drawer .....                                       | 72 |
| Setting the internal buzzer (for models with an internal buzzer) ..... | 73 |

**Chapter 4 Setting/Checking Modes**

|                                                                                                   |    |
|---------------------------------------------------------------------------------------------------|----|
| Setting/Checking Modes of TM-L90 4** models, TM-L90 Peeler 39* models .....                       | 75 |
| Self-test Mode .....                                                                              | 76 |
| NV Graphics Information Print Mode .....                                                          | 77 |
| Memory Switch Setting Mode .....                                                                  | 78 |
| Hexadecimal Dump Mode .....                                                                       | 79 |
| Setting/Checking Modes of TM-L90 other than 4** models, TM-L90 Peeler other than 39* models ..... | 80 |
| Self-test Mode .....                                                                              | 80 |
| Memory Switch Setting Mode .....                                                                  | 81 |
| Hexadecimal Dump Mode .....                                                                       | 82 |

**Chapter 5 Application Development Information**

|                                                        |    |
|--------------------------------------------------------|----|
| Introduction of Control Methods .....                  | 83 |
| Windows Driver (EPSON Advanced Printer Driver) .....   | 83 |
| EPSON OPOS ADK .....                                   | 85 |
| ESC/POS Commands .....                                 | 88 |
| Various Utilities .....                                | 89 |
| Sensors .....                                          | 89 |
| Paper Sensors .....                                    | 89 |
| Printer Cover Sensor .....                             | 90 |
| Label Peeling Sensor (Peeler Specification Only) ..... | 92 |
| Barcode Printing .....                                 | 92 |
| CODE 128 Barcode .....                                 | 93 |
| Precautions for Two-Dimensional Code Printing .....    | 97 |
| NV Memory .....                                        | 97 |
| FAQ List .....                                         | 98 |

**Chapter 6 ESC/POS Command-Related Information**

|                                                                    |     |
|--------------------------------------------------------------------|-----|
| TM Printer Operation Performed When Power Switch is Disabled ..... | 101 |
| Power Switch-Related User Operation List .....                     | 102 |
| Power Off Control by the Host .....                                | 102 |
| Head Divided Control .....                                         | 102 |
| Control After Paper Cut .....                                      | 103 |
| NV Memory .....                                                    | 103 |
| Customizing Printer .....                                          | 104 |
| Printer Initial Setting Up .....                                   | 104 |
| Changing Command Default Values .....                              | 104 |
| Using the NV Memory .....                                          | 104 |
| Printer Status .....                                               | 104 |

**Chapter 7 Handling**

|                                                                                    |     |
|------------------------------------------------------------------------------------|-----|
| Maintenance .....                                                                  | 105 |
| Autocutter (TM-L90 only) .....                                                     | 105 |
| Print Head Cleaning .....                                                          | 106 |
| Cleaning the peeler (TM-L90 Peeler Model only) .....                               | 107 |
| Troubleshooting .....                                                              | 108 |
| Panel LED and Error Status .....                                                   | 108 |
| The autocutter is jammed or the roll paper cover will not open (TM-L90 only) ..... | 115 |

|                                                                                                                    |     |
|--------------------------------------------------------------------------------------------------------------------|-----|
| When a paper jam occurs (TM-L90 Peeler Model) .....                                                                | 116 |
| The printer became inoperative after you change the interface reset signal in the memory switch setting mode ..... | 116 |
| Shipping Procedures .....                                                                                          | 117 |

*Appendix*

|                                                                                         |     |
|-----------------------------------------------------------------------------------------|-----|
| Setting items for Memory Switch Setting Mode .....                                      | 119 |
| Setting items of TM-L90 4** models .....                                                | 119 |
| Setting items of TM-L90 other than 4** models .....                                     | 123 |
| Setting items of TM-L90 Peeler 39* models .....                                         | 124 |
| Setting items of TM-L90 Peeler other than 39* models .....                              | 126 |
| Product Specifications .....                                                            | 128 |
| Product Specifications .....                                                            | 128 |
| Print Specifications .....                                                              | 131 |
| Reliability .....                                                                       | 132 |
| Character Specifications .....                                                          | 135 |
| Paper Feed Specifications .....                                                         | 136 |
| Paper Specifications .....                                                              | 136 |
| Printing Area .....                                                                     | 137 |
| Printing Position in Relation to Cutter Position (TM-L90) .....                         | 139 |
| Printing Position, Peeling Position, Manual Cutter Position (TM-L90 Peeler Model) ..... | 140 |
| Overview of External Dimensions .....                                                   | 141 |
| Interface And Connectors .....                                                          | 144 |
| RS-232 Serial Interface .....                                                           | 144 |
| IEEE1284 Parallel Interface .....                                                       | 147 |
| Option Specifications .....                                                             | 151 |
| PS-180 .....                                                                            | 151 |
| PS-190 .....                                                                            | 152 |
| Consumable Specifications .....                                                         | 153 |
| Paper Specification .....                                                               | 153 |
| Specified Roll Paper .....                                                              | 155 |
| Requirements for Receipt Paper .....                                                    | 156 |
| Requirements for Die-Cut Label Paper .....                                              | 157 |
| Requirements for Continuous Label Paper .....                                           | 162 |
| Notes on Paper Handling .....                                                           | 164 |
| Character Code Table .....                                                              | 164 |

## Chapter 1

# Product Overview

---

## 1.1 Product Structure

### 1.1.1 Models

❑ *Model*

|                                     | <b>Peeler unit</b> | <b>Power switch</b>     |
|-------------------------------------|--------------------|-------------------------|
| TM-L90 other than 4** models        | not mounted        | non-locking push button |
| TM-L90 4** models                   | not mounted        | locker switch           |
| TM-L90 Peeler other than 39* models | mounted            | non-locking push button |
| TM-L90 Peeler 39* models            | mounted            | locker switch           |

❑ *Interface*

- *Serial (RS-232C)*
- *Parallel (IEEE-1284 standard)*
- *USB (USB2.0)*
- *Ethernet (10BASE-T/100BASE-T)*
- *Wireless LAN (IEEE802.11a/b/g/n for TM-L90 4\*\* models, TM-L90 Peeler 39\* models)*
- *Wireless LAN (IEEE802.11b for the other models)*

TM-L90 4\*\* models and TM-L90 Peeler 39\* models may have the build-in-USB.

### 1.1.2 Accessories

#### TM-L90

- ❑ *Start Here*
- ❑ *Label roll paper*
- ❑ *Manual CD\**
- ❑ *Power switch cover*
- ❑ *Control panel label used for horizontal installation*
- ❑ *Paper exit guide for horizontal installation*
- ❑ *Roll paper spacer*

- Screw for installation of the roll paper spacer*
- Wire saddle\**
- AC adapter\**
- AC cable\**

\* May not be included depending on the printer model.

#### *TM-L90 Peeler Model*

- Start Here*
- Label roll paper*
- Manual CD\**
- Power switch cover*
- Operation label (an instruction label for the peeler open lever and the cover open lever)*
- Roll paper spacer*
- Screw for installation of the roll paper spacer*
- Wire saddle*
- AC adapter \**
- AC cable \**

\* May not be included depending on the printer model.

#### **1.1.3 Option**

- Affixing tapes (model: DF-10)*
- Wall hanging bracket (model: WH-10)*
- AC adapter PS-180/PS-190*
- Power cables*

## 1.2 Name and Description of Each Part

### 1.2.1 Part Names (TM-L90)

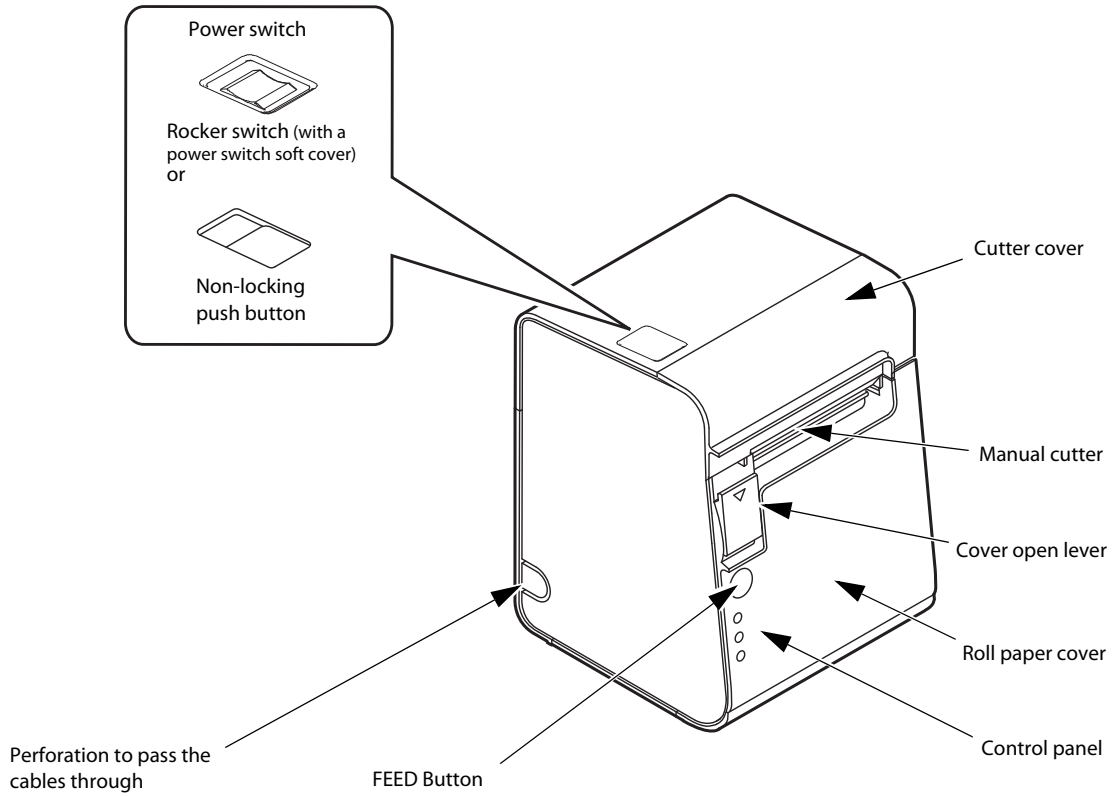

#### Printer Part Names

\* Refer to [page 42](#) for the location of the DIP switches (available only for TM-L90 other than 4\*\* models).

### 1.2.2 Part Names (TM-L90 Peeler Model)

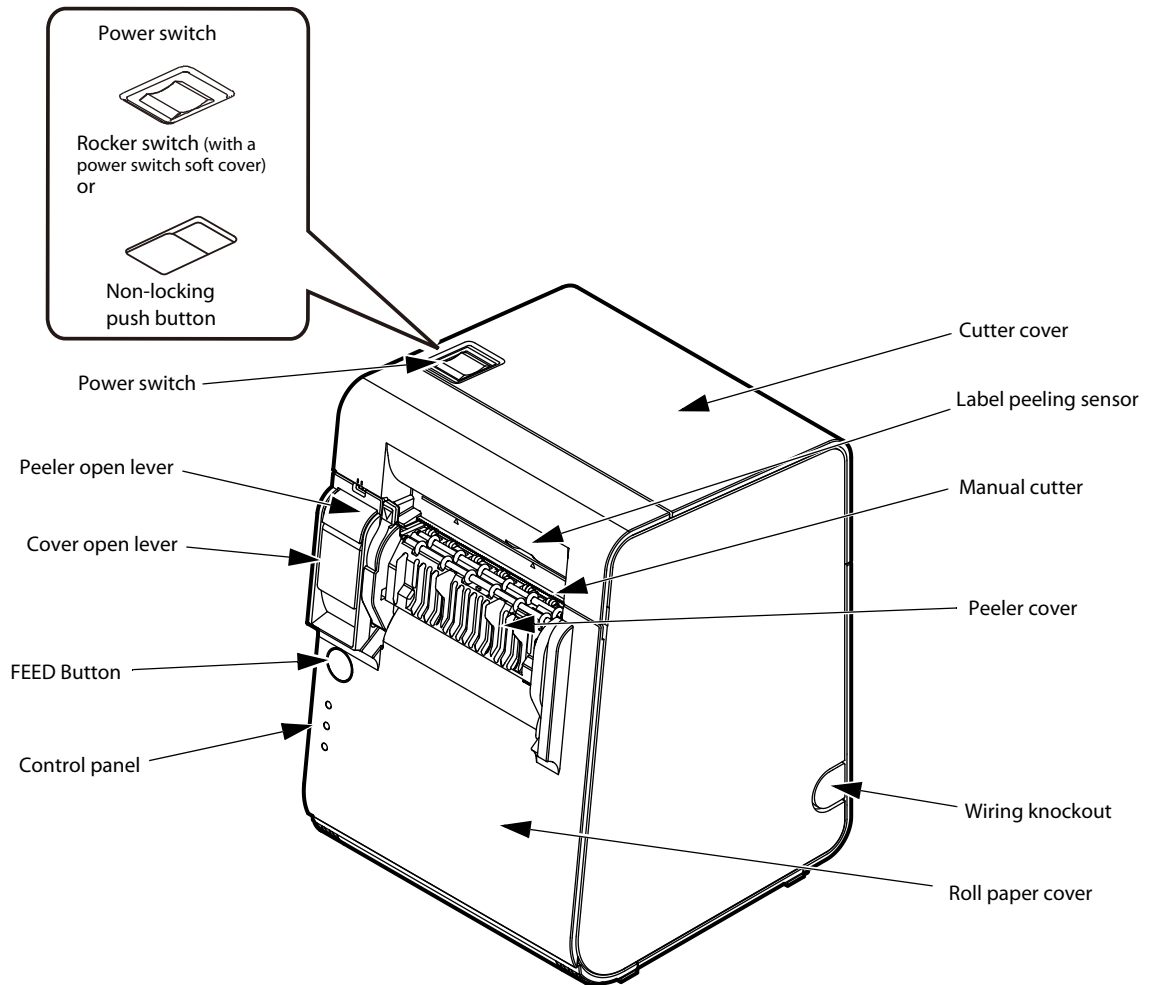

Part Names of TM-L90 Peeler Model

\* Refer to [page 42](#) for the DIP switch positions. (available only for TM-L90 Peeler other than 39\* models)

### 1.2.3 Paper FEED button inside the printer

Another FEED button is located under the roll paper cover.

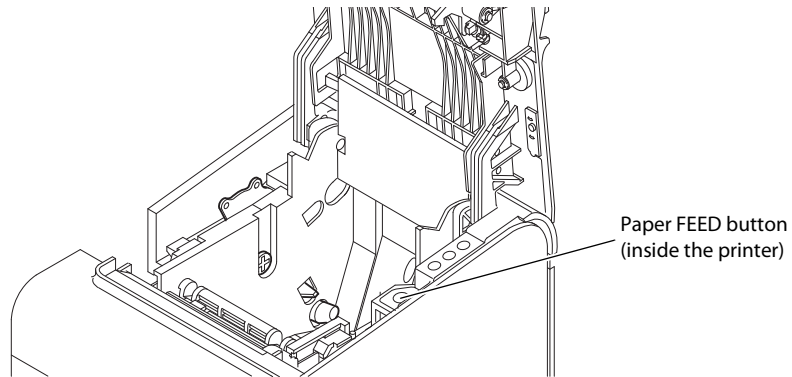

### 1.2.4 Control Panel

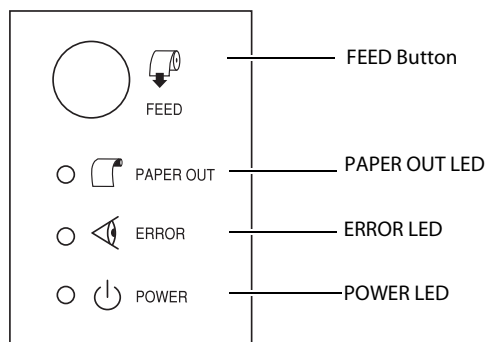

#### FEED button (with the TM-L90)

When using label paper or receipt paper with black mark:

- ❑ Pressing this button feeds paper to the next print starting position.

When using receipt paper:

- ❑ Pressing this button once feeds paper by one line. Holding this button down feeds paper continuously.

#### FEED button (with the TM-L90 Peeler Model)

When using label paper or receipt paper with black mark:

- ❑ Pressing this button feeds paper to the next print starting position.
- ❑ Pressing this button after opening/closing the roll paper cover initializes the mechanism. (After closing the roll paper cover, the status changes to waiting to print when FEED button is pressed)
- ❑ When error recovery with FEED button is enabled by memory switch 8-1, if a paper layout error occurs, pressing FEED button recovers from the error and performs automatic paper layout.

When using receipt paper:

- ❑ Pressing this button once feeds paper by one line. Holding this button down feeds paper continuously.

#### PAPER OUT LED (with the TM-L90)

- ❑ Lights when there is no more roll paper or there is little remaining. (Default setting. The LED condition varies according to the memory switch settings. Refer to ["Memory Switch Settings" on page 42](#) and ["Error Code" on page 110](#) for details.)
- ❑ Off when there is a sufficient amount of roll paper remaining. (Default setting. The LED condition varies according to the memory switch settings. Refer to ["Memory Switch Settings" on page 42](#) and ["Error Code" on page 110](#) for details.)
- ❑ Flashes when a self test is in progress or when the printer waits for the macro execution switch to go on.

#### PAPER OUT LED (with the TM-L90 Peeler Model)

- ❑ Lights when there is no more roll paper or there is little remaining. (Default setting. The LED condition varies according to the memory switch settings. Refer to ["Memory Switch Settings" on page 42](#) and ["Error Code" on page 110](#) for details.)
- ❑ Off when there is a sufficient amount of roll paper remaining. (Default setting. The LED condition varies according to the memory switch settings. Refer to ["Memory Switch Settings" on page 42](#) and ["Error Code" on page 110](#) for details.)
- ❑ Flashes when a self test is in progress or when the printer waits for the macro execution switch to go on.
- ❑ When the roll paper is inserted and the roll paper cover is closed, one label is ejected and the LED starts flashing. It flashes until FEED button is pressed.
- ❑ When a label is issued, flashing starts after it is issued. The LED flashes until the label is removed from the peeler.

#### POWER LED

- ❑ Lights when the power supply is on.
- ❑ Off when the power supply is turned off.
- ❑ Flashes during execution of each operation.

#### ERROR LED

- ❑ Lights when the printer is offline.
- ❑ Off under normal conditions.
- ❑ Flashes when an error occurs. (Refer to ["Error Code" on page 110](#) for details)

## 1.2.5 Power Switch

Refer to "[Printer Part Names](#)" on page 13 for the power switch location. The type of the power switch differs, depending on models and functions may differ, depending on the models. Therefore, be sure to check the type of the power switch of your printer and a model number on the manufacturer's plate of your printer.

Rocker switch (TM-L90 4\*\* models, TM-L90 Peeler 39\* models):

Turns the printer on or off. The marks on the switch: (  / | )

Non-locking push button (TM-L90 other than 4\*\* models, TM-L90 Peeler other than 39\* models):

Turn on the power by holding down the POWER button 1 second or longer. Turn off the power by holding down the POWER button 3 seconds or longer.

The printer is normally turned on/off with this switch. You can select whether to enable or disable the power switch using the DIP switches.

When the DIP switches are set to OFF (power switch enabled), the power switch controls the TM printer as follows.

When the TM is turned off:

The TM printer is powered ON when the power switch is pressed more than 1 second.

When the TM is turned on:

The TM printer is powered OFF when the power switch is pressed more than 3 seconds.

If for some reason pressing the power switch even more than 10 seconds does not turn the power off, the TM printer executes a forced power off.



**Note:**

When the DIP switches are set to ON (power switch disabled), use direct control of the printer with ESC/POS commands. (For details, refer to "[TM Printer Operation Performed When Power Switch is Disabled](#)" on page 101.)



**Note:**

Make sure to check whether the AC adapter is connected to the power supply before turning on the power switch of the printer.

## 1.2.6 Power Switch Cover

To prevent unintentional contact or improper changes and to improve the appearance, use a power switch cover. When using the power switch cover, to turn on or off the TM printer, press the power switch through the hole in the power switch cover. Attach the cover as shown in the illustrations below.

TM-L90 4\*\* models, TM-L90 Peeler 39\* models

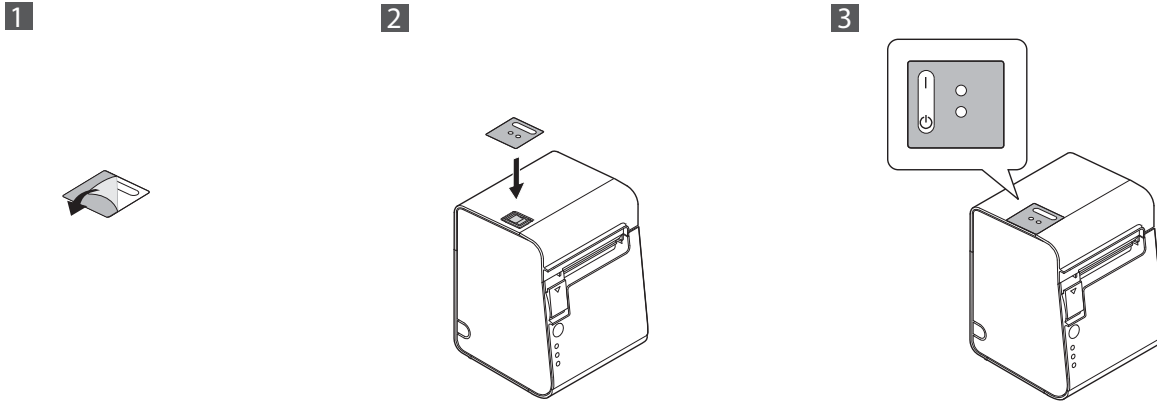

TM-L90 other than 4\*\* models, TM-L90 Peeler other than 39\* models

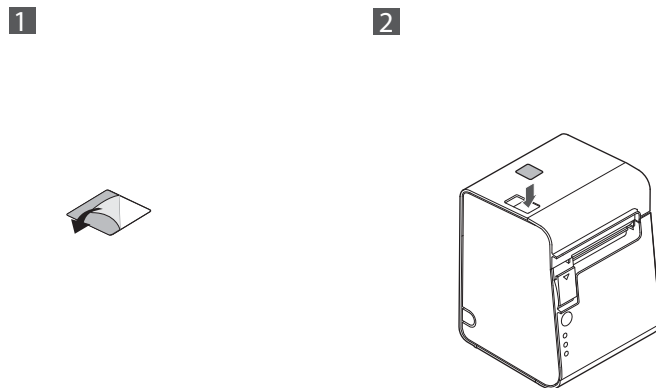

### **WARNING:**

*If an accident occurs with the power switch cover attached, unplug the power cord immediately. Continued use may cause fire or shock.*

### **CAUTION:**

*Do not remove the power switch soft cover. (only for TM-L90 4\*\* models and TM-L90 Peeler 39\* models)*

### 1.2.7 Mode Switch (TM-L90 Peeler Model Only)

With the TM-L90 Peeler Model, you can select the peeling issuing mode and continuous issuing mode with the mode switch. The mode switch switches between the peeling issuing mode and continuous issuing mode.

The mode switch is inside the top left of the printer when the roll paper cover is opened.



Be sure that the peeler cover and the roll paper cover are open when switching the modes. The setting is effective when the power is turned on or the covers are closed. If the mode is switched with the covers closed, the setting will not be changed.

Be sure not to use a ball point pen to switch the modes. A ball point pen can damage the switch.

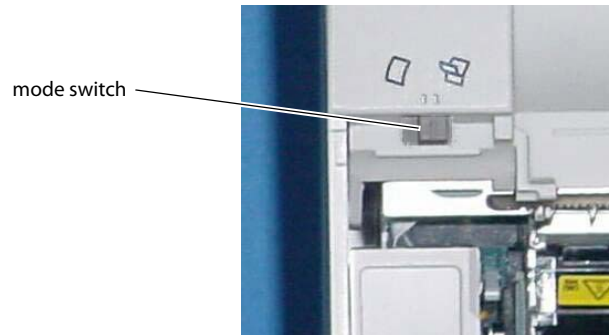

To use the peeling issuing mode, move the mode switch to the right.

To use the continuous issuing mode, move the mode switch to the left.

## 1.2.8 Connectors

Remove the bottom of the cover as shown in the illustration below. All cables are connected to the connector panel located on the lower rear side of the printer.

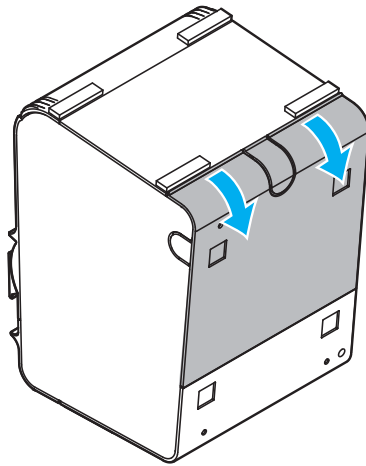

The connector panel differs, depending on the models.

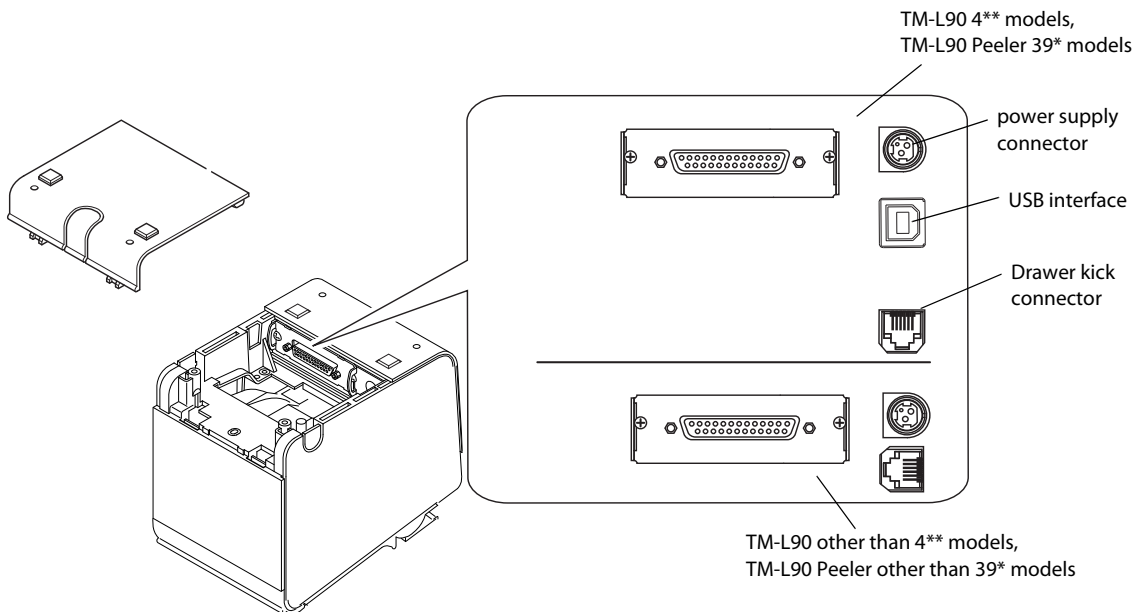

Connector Panel



**Note:**

The model pictured is a serial interface model. For other information on interfaces and connectors, refer to ["Connecting the Cable" on page 63](#).

## Chapter 2

---

# Setup

### 2.1 Setup Flow

Before using the printer, you need to set various settings to increase the printer's functionality. Configure the printer appropriately depending on the environment.

Determine how to install the printer (install it vertically or horizontally)



Set the Roll Paper Near-End Detector



Connect the AC adapter



Autocutter settings (TM-L90 only)



Set the Roll Paper width



DIP switch settings



Memory switch settings



Set the Paper layout

---

## **2.2 Installation Procedures**

### **2.2.1 Precaution For Installation**

#### ❑ TM-L90

- Locate the printer on a flat surface, whichever orientation you choose.
- Avoid locations susceptible to dust and other foreign matter.
- Avoid resting the printer on the power supply or other cables or other objects.
- Consider vibration during paper cutting and drawer usage. Take measures to prevent the printer from moving.

#### ❑ TM-L90 Peeler Model

- Locate the printer on a flat surface.
- Avoid locations susceptible to dust and other foreign matter.
- Avoid resting the printer on the power supply or other cables or other objects.
- Consider vibration during paper cutting and drawer usage. Take measures to prevent the printer from moving.
- To prevent malfunction of the label peeling sensor, do not locate the printer in direct sunlight.

### 2.2.2 Instructions for Installation

The TM-L90 can be placed vertically (paper outlet in front), horizontally (paper outlet at the top), or attached to a wall (using the optional wall hanging set WH-10).

With the TM-L90 Peeler Model, you can use it vertically or wall mounted with either peeling issuing or with continuous issuing (not using the peeler).



**Note:**

*For the TM-L90 Peeler Model, horizontal installation is prohibited to avoid jams caused by re-sticking of backing paper and a label.*

The illustration below shows the vertical installation for the TM-L90 Peeler Model.



**Note:**

*To hang the printer on the wall, see the Wall Hanging Bracket Set Installation Manual provided with the WH-10 for instructions.*

*It is recommended to take some measures so that the printer will be stable when paper is being loaded or a drawer is being used. The DF-10 (affixing tapes) for fixing the printer is provided as an option.*

*When using the printer with the peeling issuing mode, be sure to install the printer so that a peeled label will not contact the used backing paper. Re-sticking of a peeled label to the backing paper will cause jams.*

For the TM-L90, when changing the way of installation, you need to adjust the following items:

- Control panel label used for horizontal installation
- The location of the Roll Paper Near-End Detector

The following figure shows the TM-L90 placed both vertically and horizontally.



When you install the printer horizontally, attach the control panel label as shown in the illustration below.

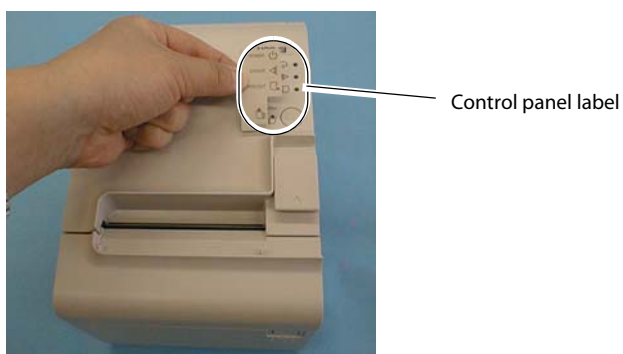

**Note:**

To hang the printer on the wall, see the *Wall Hanging Bracket Set Installation Manual* provided with the WH-10 for instructions.

When you use TM-L90 horizontally, peel off the backing sheet of the paper exit guide and attach it as shown below to prevent cut paper from falling inside the printer after paper is cut by the autocutter.



**CAUTION:**

When using the paper exit guide, do not use roll paper with a core that is smaller than the specification (inside diameter: 25.4 mm, outside diameter: 31.4 mm). Using a smaller one may cause a paper jam at the attached paper exit guide.

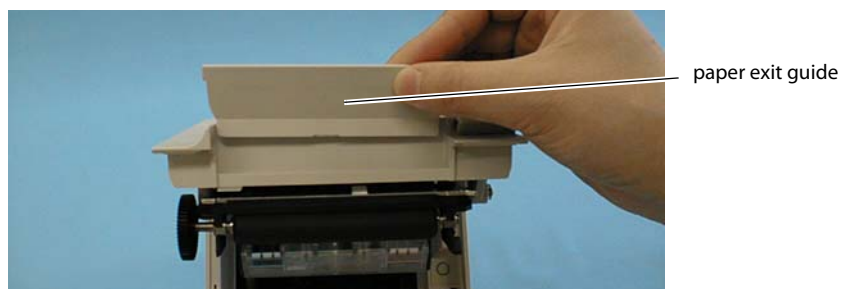

## 2.3 Adjusting Roll Paper Near-End Detection Position

### 2.3.1 With TM-L90

Below are three situations when roll paper N.E. detector adjustment is required.

- ❑ When changing the way of installation. (Vertically ↔ Horizontally)
- ❑ To adjust the location of detection to suit the diameter of the roll paper core used.
- ❑ To adjust the amount of remaining paper desired.



**Note:**

Roll paper centers are manufactured according to various specifications, making it impossible to exactly detect the remaining amount of paper.

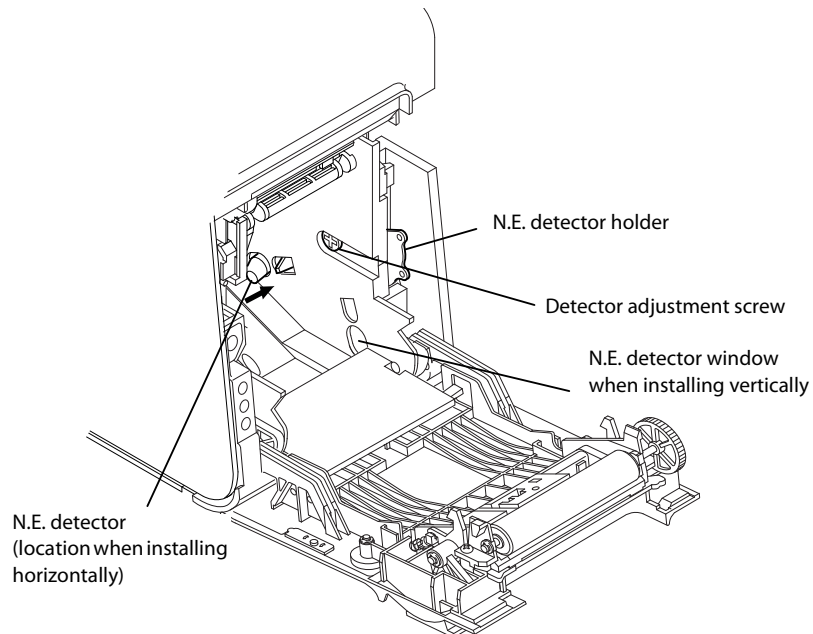

*Part names and the locations of N.E. detector components*

1. Open the roll paper cover.
2. Remove the roll paper.

3. Loosen the detector adjustment screw using a coin or similar tool.

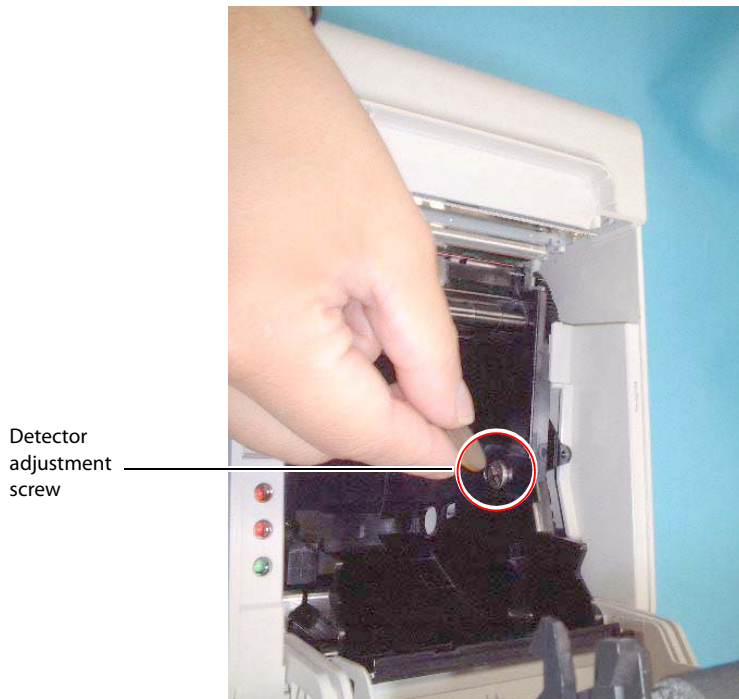

4. The adjustment position of the roll paper Near-End detector changes depending on the way of installation. In either case (vertical or horizontal), adjust the detector so that its tab comes out from the hole near the bottom of the printer. (Refer to "[Adjusting Roll Paper Near-End Detection Position](#)" on page 25, "[Adjustment Positions of N.E. Detector](#)" on page 27.

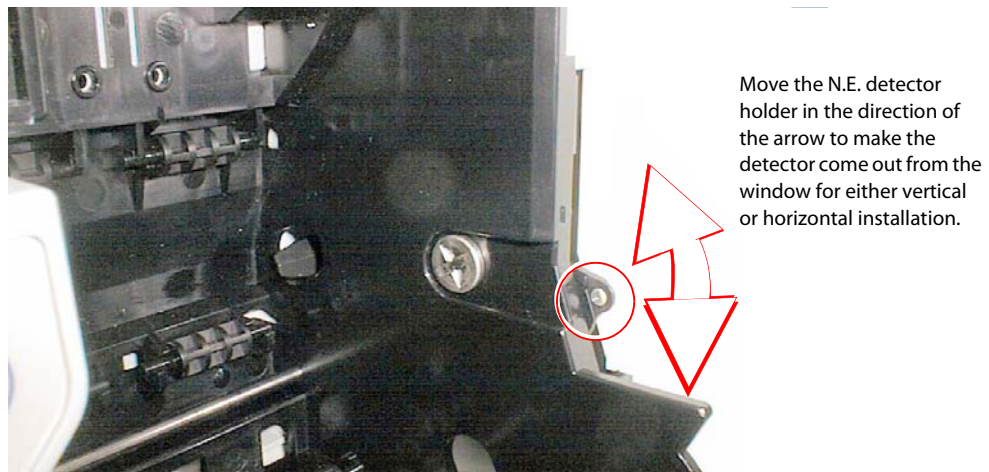

**Note:**

*When changing the position of the N.E. detector in accordance with the change of installation, move the roll paper N.E. detector as the above arrow shows while holding down the detector.*

- To fine tune the amount of remaining paper that is detected by the N.E. detector, move the N.E. detector holder shown in the illustration "N.E. Detector Holder" on page 27 and adjust the position.



**Note:**

Note that the direction to move the roll paper N.E. detector varies depending on the method of printer installation (vertical/horizontal).

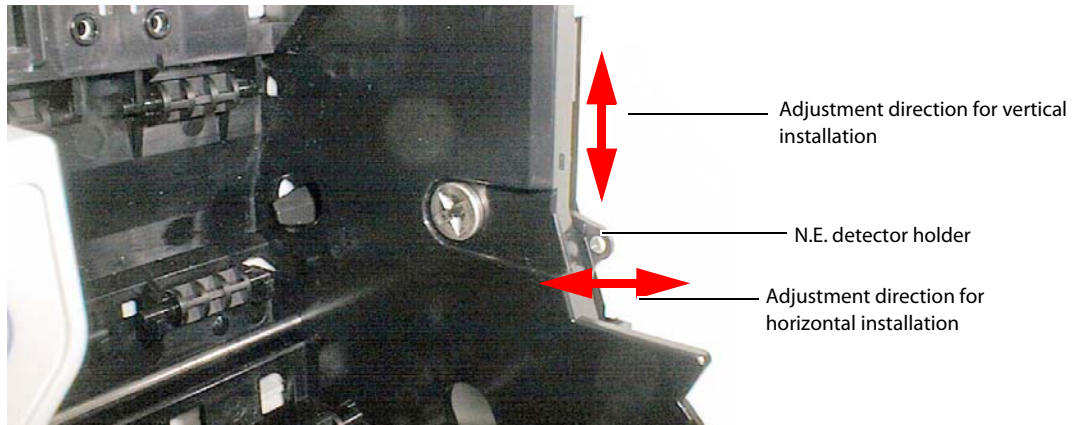

N.E. Detector Holder

| Adjustment Position Number | Specified Thermal Paper Dimension |
|----------------------------|-----------------------------------|
| #1                         | Approximately 36 mm {1.42"}       |
| #2                         | Approximately 41 mm {1.61"}       |

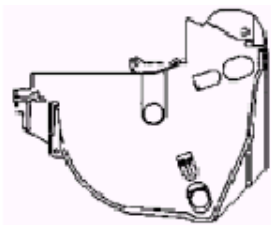

Holder Position #1 for horizontal

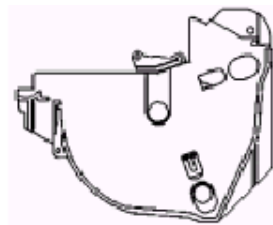

Holder Position #2 for horizontal

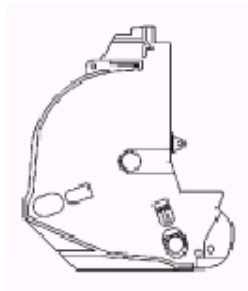

Holder Position #1 for vertical

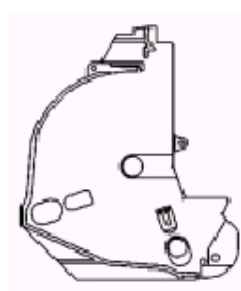

Holder Position #2 for vertical

Adjustment Positions of N.E. Detector

6. Tighten the detector adjustment screw using a coin or similar tool.
7. Move the N.E. detect lever by hand (finger) to confirm that it moves smoothly.

Check that the N.E. detect lever is operating properly.

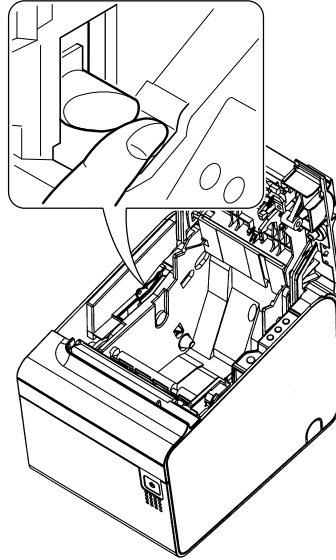

8. Load the roll paper.
9. Close the roll paper cover.

### 2.3.2 With the TM-L90 Peeler Model

In the following 2 cases, it is necessary to adjust the position of the roll paper near end sensor.

- ❑ When adjusting the detection position according to the thickness of the roll paper core
- ❑ When adjusting the amount remaining paper desired

 **Note:**

Since the shape of the central part of the roll paper may differ slightly according to the specification, it is not possible to detect near end exactly.

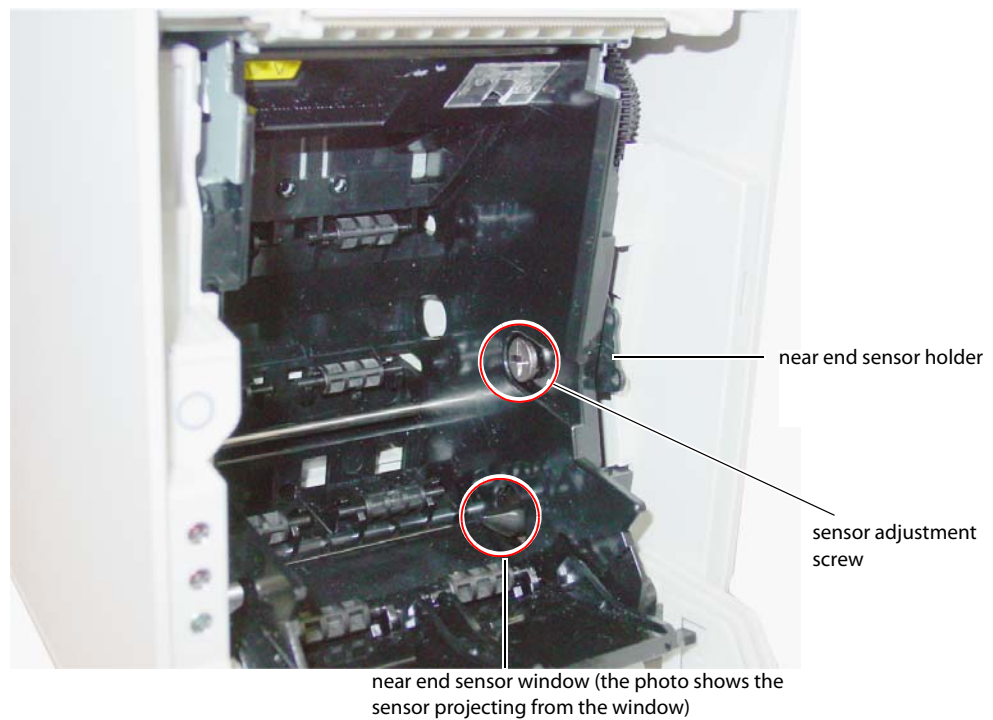

*Part names and the locations of N.E. detector components*

1. Open the peeler cover.
2. Open the roll paper cover.
3. Take out the roll paper.

- Using a coin or similar tool, loosen the sensor adjustment screw.

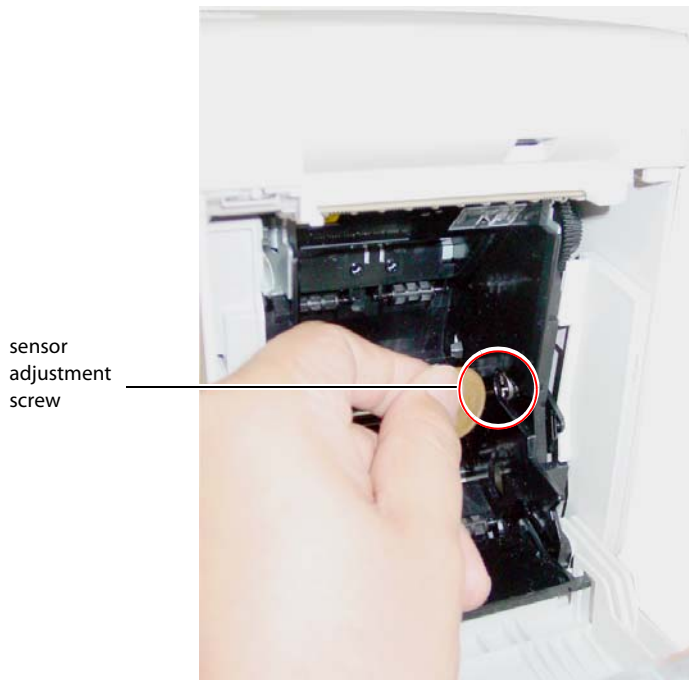

- Adjust the roll paper near end sensor so that the claw of the roll paper near end sensor projects from the hole near the bottom of the device. (Refer to ["Part names and the locations of N.E. detector components"](#) on page 25 and ["Near end sensor adjustment position"](#) on page 31.)



Adjust the sensor so that it projects from the window.

- To make fine adjustments to the amount of paper remaining detected by the roll paper near end sensor, finely adjust the position of the near end sensor holder by moving it in the direction of the arrows as shown in the figure ["N.E. Detector Holder"](#) on page 27.

 **Note:**

Move the N.E. detector in the direction shown by arrow.

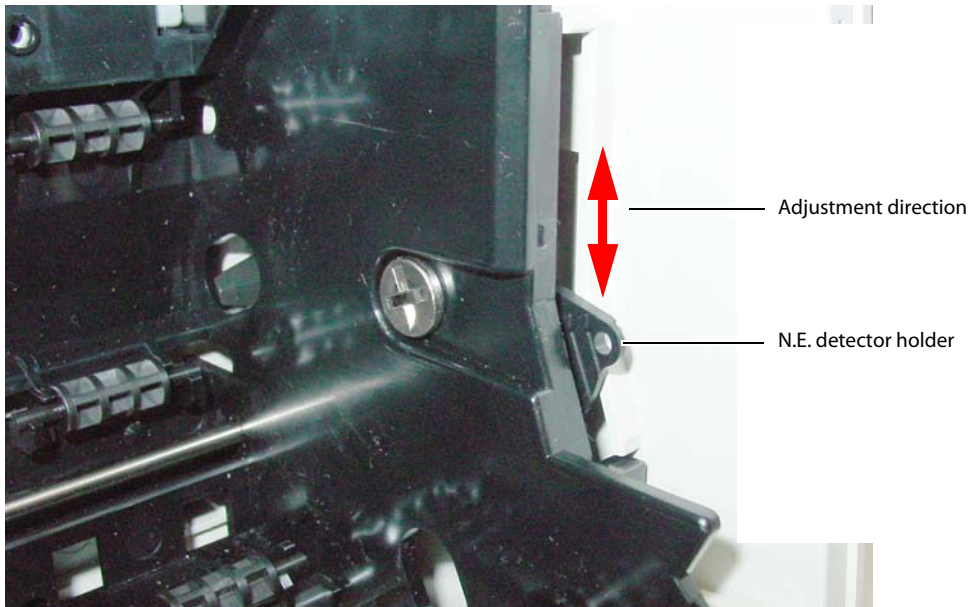

Near end sensor holder

| Adjustment scale | Outside diameter of specified thermal paper |
|------------------|---------------------------------------------|
| #1               | Approximately 36 mm {1.42"}                 |
| #2               | Approximately 41 mm {1.61"}                 |

 **Note:**

Adjust the sensor while checking the position of the parts circled in the following figure.

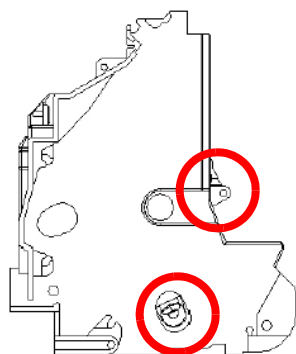

when the sensor holder position is #1 when placed vertically

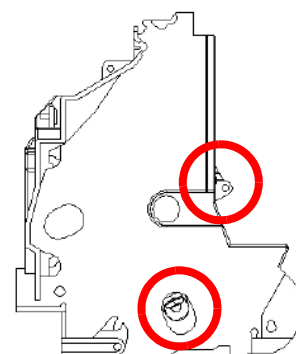

when the sensor holder position is #2 when placed vertically

Near end sensor adjustment position

7. Using a coin or similar tool, tighten the sensor adjustment screw.
8. Push the near end sensor with your finger and check that it moves smoothly.

push the near end sensor with your finger and check that it moves smoothly

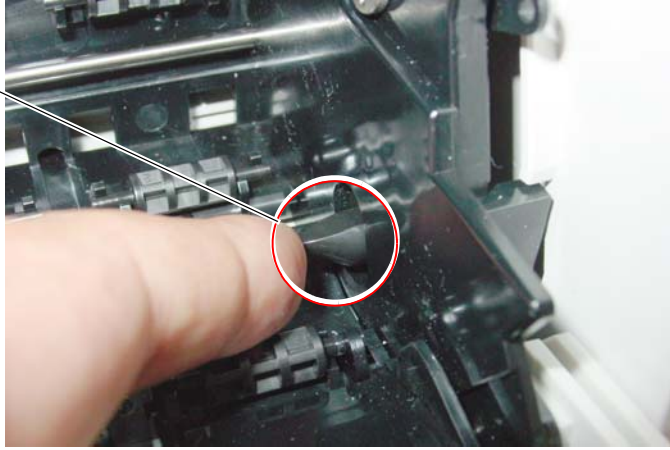

9. Set the roll paper.
10. Close the roll paper cover.

## **2.4 Connecting AC adapter (PS-180/PS-190)**

Be sure to use the PS-180/PS-190 or the equivalent product as the AC adapter.

### **CAUTION:**

*Be sure to remove the AC cable from the wall outlet whenever connecting or disconnecting the AC adapter to the printer. Failure to do so may result in damage to the AC adapter or the printer.*

*Be sure to confirm that the wall outlet power supply satisfies the rated voltage requirements of the AC adapter. Never insert the AC cable plug into a socket that does not meet the rated voltage requirements of the AC adapter. Doing so may result in damage to both the AC adapter and the printer.*

### **2.4.1 Attaching AC adapter**

The following is an explanation of the procedure for attaching the power unit to the TM-L90.

1. Confirm that the printer's power supply is turned off and the AC adapter's AC cable has been removed from the wall outlet.
2. To place cables, first break off by hand any of the three perforations to pass the cables through indicated by circles in the illustration (the other one is on the right). Then put the cables through the holes and replace the bottom of the cover.



3. Remove the bottom of the cover as shown in the illustration below.

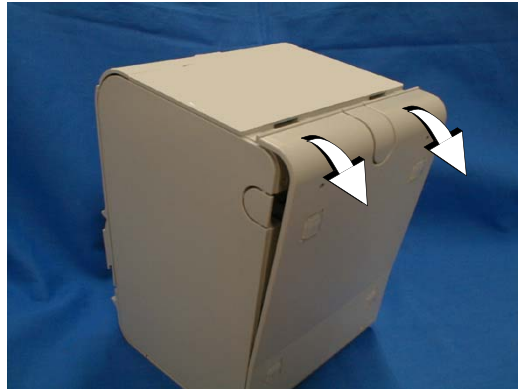

4. Install the connector of the DC cable onto the DC connector (labeled DC24V).



Power supply connector

*Power Supply Connector*



**Note:**

*The connector panel varies depending on the models.*

*When removing the DC cable connector from the printer, first confirm that the AC cable has been disconnected from the wall outlet; then grasp the arrow marked section of the connector and pull straight out.*

### **2.4.2 Caution about AC adapter and Supply Voltage**

- ERROR LED flashes when a high voltage or low voltage error occurs. In such cases, immediately turn the power off.

Refer to "[Unrecoverable errors](#)" on page 113 for the LED flashing patterns.

## 2.5 Autocutter Settings (TM-L90 only)

The TM-L90 has an autocutter attached for cutting the paper. The autocutter can perform 2 cuts, "partial cut," in which a small part is left uncut on the left edge, and "full cut" (default setting), in which the paper is cut completely. By adjusting the attachment position of the cutter unit, you can select between "partial cut" and "full cut."



**Note:**

You can't configure the autocutter setting (Partial cut/Full cut) through a software command.

You can't change from partial cut setting to full cut setting after using the printer with partial cut setting. Since the partial cut doesn't use the tip of the blade, it might have deteriorated. Contact the nearest Epson service center if you'd like to do the above change.

To disable the autocutter, change the memory switch (MSW2-2) settings. (Refer to ["Memory Switch Settings" on page 42](#)).

Performing full cut without the paper exit guide when the printer installed horizontally may cause a double-cut, paper jam or autocutter error because a cut sheet may drop in the paper path. Be sure to attach the paper exit guide when performing a full cut in the horizontal installation. (Refer to ["Instructions for Installation" on page 23](#) for instructions on attaching the guide.)

### 2.5.1 Cautions on the Lengths of the Receipts/Labels to Issue

- To prevent the cut receipts or labels from getting stuck in the paper path, causing paper jams.
- To make the cut receipts or labels easy to remove

The lengths of the receipts and labels to issue is recommended as shown in the table below.

| Use condition                                       | Recommended issuing length |
|-----------------------------------------------------|----------------------------|
| Horizontal installation (full cut)* <sup>1</sup>    | 37.5 mm or more            |
| Horizontal installation (partial cut)* <sup>2</sup> | 25.4 mm or more            |
| Vertical installation                               |                            |

Note 1: Install the paper exit guide packed in the box with the printer when the autocutter is used with a full cut, with the printer positioned horizontally.

2: Partial cut (one point left uncut) is available only when using receipt paper or continuous label paper without black marks. Also, do not perform cutting and reverse feed together.



**Note:**

If the lengths of receipts or labels are specified shorter than the recommended lengths, the issued receipts or labels may be hard to remove. Users must make a thorough evaluation of the lengths to specify before using the printer.

### 2.5.2 Setting Procedure

1. Turn off the power.
2. Pull the cover open lever, and open the roll paper cover.
3. Push the body case outward (in the direction of the 2 arrows) and remove the cutter cover.

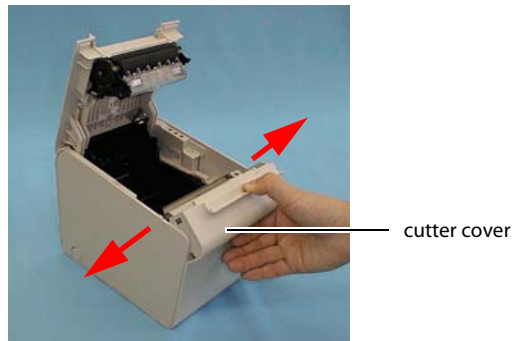

4. Remove the single screw retaining the cutter unit and loosen the screw indicated by the circle in the illustration below.

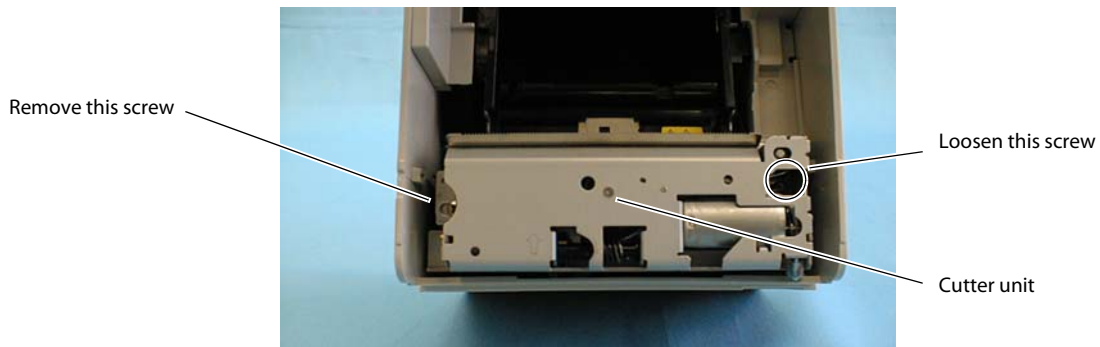

5. Lift the top of the cutter unit upward and remove it.

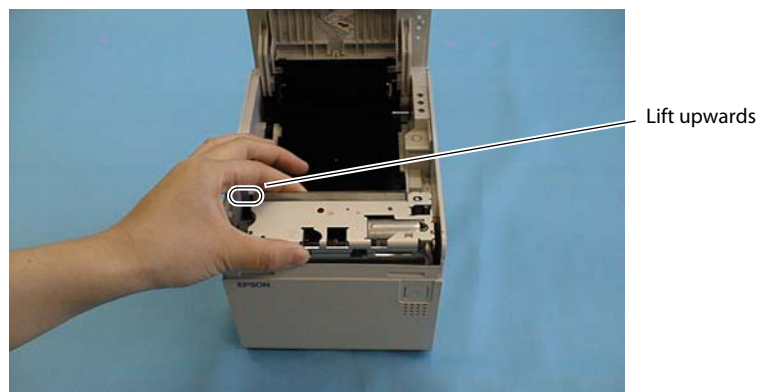

- Moving the cutter unit in a lateral direction, shift to the dowel position of the desired cut method.

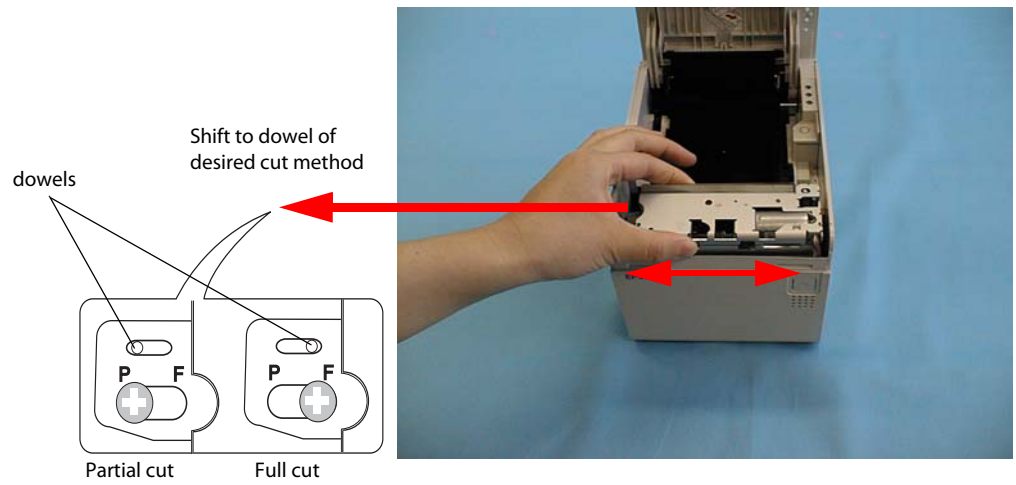

- Secure the cutter unit again using the removed screw and the loosened screw.
- Install the cutter cover.
- Close the roll paper cover.

## 2.6 Setting Roll Paper Width

The TM-L90 / TM-L90 Peeler Model uses a roll paper 80 mm wide in the default state. When using a roll paper 38 to 70 mm wide with this printer, attach the roll paper spacer in accordance with the following procedure.



**Note:**

*If a printer has already been used, the paper width cannot be changed from narrow to wide. This is because the part of the head that made direct contact with the platen may have been damaged when narrow roll paper was used. The paperless part of the cutter blade may also have worn. Only when the printer is not yet used can the paper width be changed from narrow to wide.*

The following explains the procedure for setting the roll paper width for the TM-L90.

1. When using 61 mm to 70 mm roll paper, break off the two tabs of the roll paper spacer.



**Note:**

*You can still use widths from 38 mm to 60 mm after breaking the tabs off.*

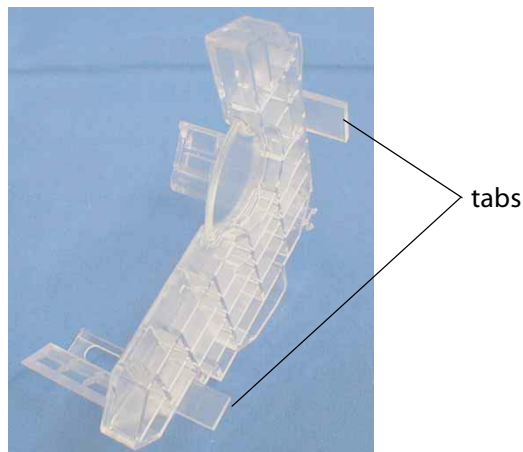

2. Open the roll paper cover.
3. As shown below, insert the roll paper spacer so that the front edge goes through the notch in the printer, and fit the protrusion of the roll paper spacer on the shaft.

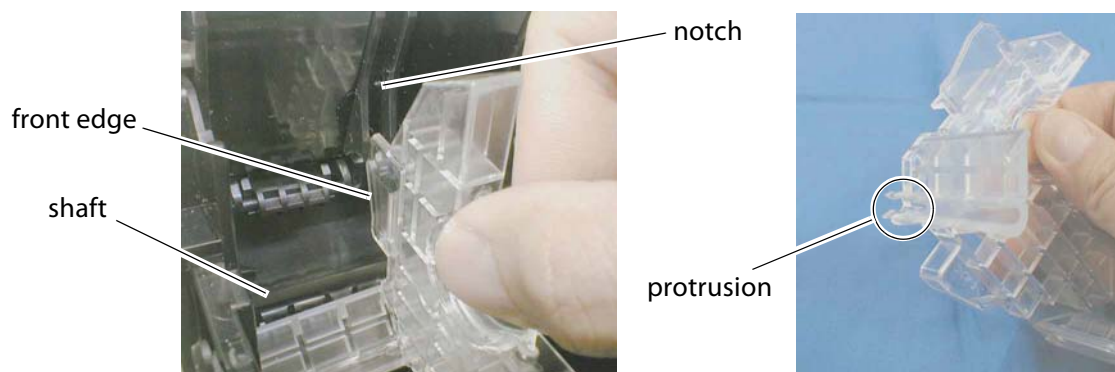

4. Push the roll paper spacer until it clicks.



**Note:**

Check that the roll paper spacer slides smoothly from side to side.

5. Slide the roll paper spacer side-to-side and set it to the appropriate position. Use the measurement lines if necessary.



**Note:**

Roll paper is placed on the tab-free side of the roll paper spacer.

When positioning the roll paper spacer, provide 0.5 mm of room for the maximum roll paper width.

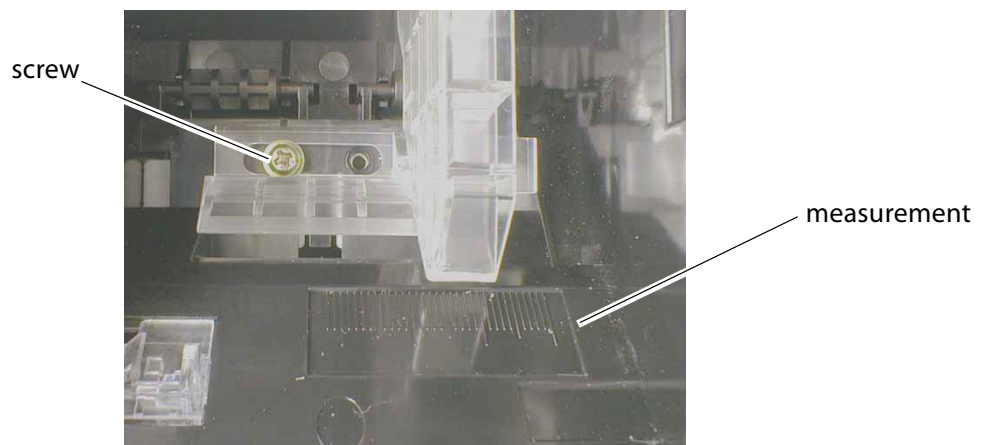

6. Secure the roll paper spacer with the supplied screw. (See above.)
7. Make the setting for the paper width with the memory switch.  
For information about the memory switch, see ["Memory Switch Settings" on page 42.](#)

## **2.7 DIP Switch Settings**

The following models have the DIP switches for settings.

- ❑ TM-L90 other than 4\*\* models
- ❑ TM-L90 Peeler other than 39\* models

The DIP switches are located inside the printer as shown the picture below.



Before setting DIP switches, remove the DIP switch cover.



**Note:**

*Set the DIP switches after turning off the printer. The settings will not be enabled if they are set with the power on.*



DIP switch settings (Serial interface model)

| SW No. | Function                                   | ON                                                                       | OFF                                          | Initial Setting |     |
|--------|--------------------------------------------|--------------------------------------------------------------------------|----------------------------------------------|-----------------|-----|
| 1      | Enable/disable Power switch.               | Switches power supply On/Off using commands. (Power switch is disabled.) | Power switch is used to switch power On/Off. | OFF             |     |
| 2      | Select for serial communication condition. | Set using DIP switch 1-7, 1-8                                            | Set using memory switches.                   | ON              |     |
| 3      | Handshake                                  | XON/XOFF                                                                 | DTR/DSR                                      | OFF             |     |
| 4      | Bit length                                 | 7 bits                                                                   | 8 bits                                       | OFF             |     |
| 5      | Parity check                               | Yes                                                                      | No                                           | OFF             |     |
| 6      | Parity type                                | Even                                                                     | Odd                                          | OFF             |     |
| 7      | Baud rate (bps)                            | 7                                                                        | 8                                            | OFF             |     |
| 8      |                                            | ON                                                                       | ON                                           | :2400           | OFF |
|        |                                            | OFF                                                                      | ON                                           | :4800           |     |
|        |                                            | ON                                                                       | OFF                                          | :9600           |     |
|        | OFF                                        | OFF                                                                      | :19200                                       |                 |     |

bps: Indicates the number of bits transferred per second.

DIP switches 2 to 8 are for serial communication. Not used in parallel communication.

 **Note:**

When you set the baud rate with the memory switch, you can set faster communication than with the DIP switch. (Refer to "Memory Switch Settings" on page 42, "Error Code" on page 110)

In serial communication, intermittent printing\* may occur. This is because when the communication speed is low, a data transmission waiting state occurs frequently since the printing mechanism speed is high. Increasing the communication speed may reduce this symptom.

\* Intermittent printing: White streaks as large as one or two hairs appear horizontally in a printing result.

DIP switch settings (Parallel, USB, Ethernet model)

| SW No. | Function                     | ON                                                                       | OFF                                          | Initial Setting |
|--------|------------------------------|--------------------------------------------------------------------------|----------------------------------------------|-----------------|
| 1      | Enable/disable Power switch. | Switches power supply On/Off using commands. (Power switch is disabled.) | Power switch is used to switch power On/Off. | OFF             |
| 2      | Reserved                     | Fixed to on                                                              | --                                           | ON              |
| 3      | Reserved                     | --                                                                       | Fixed to off                                 | OFF             |
| 4      | Reserved                     | --                                                                       | Fixed to off                                 | OFF             |
| 5      | Reserved                     | --                                                                       | Fixed to off                                 | OFF             |
| 6      | Reserved                     | --                                                                       | Fixed to off                                 | OFF             |
| 7      | Reserved                     | --                                                                       | Fixed to off                                 | OFF             |
| 8      | Reserved                     | --                                                                       | Fixed to off                                 | OFF             |

bps: Indicates the number of bits transferred per second.

DIP switches 2 to 8 are for serial communication. Not used in parallel communication.

---

## 2.8 Memory Switch Settings

The printer has the following software switches, called memory switches, in the non-volatile memory.

- Msw1, Msw2, Msw5, Msw7, Msw8
- Customized values
- Serial communication conditions
- USB communication conditions



**Note:**

*Msw5, Msw7, and USB communication conditions are available only for TM-L90 4\*\* models or TM-L90 Peeler 39\* models.*

These settings can be made by the Memory Switch Setting Utility (see [page 89](#)), the Memory Switch Setting Mode (see [page 42](#)), or ESC/POS commands.

For details of ESC/POS commands, refer to the “ESC/POS Command Reference”. For details on how to obtain this manual, see ["Introduction of Control Methods" on page 83](#).

For usage of the Memory Switch Setting Utility, refer to the user's manual of the utility.

For usage of the Memory Switch Setting Mode, see ["Memory switches of TM-L90" on page 43](#) for TM-L90 4\*\* models, TM-L90 Peeler 39\* models, or ["Memory switches of TM-L90 Peeler Model" on page 48](#) for TM-L90 other than 4\*\* models, TM-L90 Peeler other than 39\* models.

### 2.8.1 Memory switches of TM-L90

In the following tables, “✓” shows that the setting can be set by the utility or the setting mode.

#### Msw1

| Msw | Function                          | Off                            | On                  | Initial setting | Msw Setting utility | Msw Setting Mode |
|-----|-----------------------------------|--------------------------------|---------------------|-----------------|---------------------|------------------|
| 1-1 | Transmission of Power-on notice   | Disabled                       | Enabled             | Off             | ✓                   | ✓                |
| 1-2 | Receive buffer capacity           | 4 Kbytes                       | 45 bytes            | Off             | ✓                   | ✓                |
| 1-3 | BUSY condition                    | Receive buffer full or Offline | Receive buffer full | Off             | ✓                   | ✓                |
| 1-4 | Data processing for receive error | Replaced with "?"              | Ignored             | Off             | ✓                   | ✓                |
| 1-5 | Automatic line feed               | Disabled                       | Enabled             | Off             | ✓                   | ✓                |
| 1-6 | (Reserved)                        | Fixed to Off                   |                     | Off             |                     |                  |
| 1-7 | #6 pin of RS-232                  | Not used                       | Used for reset      | Off             | ✓                   | ✓                |
| 1-8 | #25 pin of RS-232                 | Not used                       | Used for reset      | Off             | ✓                   | ✓                |

[Msw1-4], [Msw1-7], [Msw1-8]: Valid only for serial interface

[Msw1-5]: Valid only for parallel interface

[Msw1-7], [Msw1-8]: Not available for TM-L90 4\*\* models

#### Msw2

| Msw        | Function            | Off                         | On      | Initial setting | Msw Setting utility | Msw Setting Mode |
|------------|---------------------|-----------------------------|---------|-----------------|---------------------|------------------|
| 2-1        | (Reserved)          | Fixed to On (Do not change) |         | On              |                     |                  |
| 2-2        | Autocutter function | Disabled                    | Enabled | On              | ✓                   | ✓                |
| 2-3 to 2-8 | (Reserved)          | -                           | -       | Off             |                     |                  |

*Msw5 (only for 4\*\* models)*

| <b>Msw</b> | <b>Function</b>                              | <b>Off</b>                                                        | <b>On</b>      | <b>Initial setting</b> | <b>Msw Setting utility</b> | <b>Msw Setting Mode</b> |
|------------|----------------------------------------------|-------------------------------------------------------------------|----------------|------------------------|----------------------------|-------------------------|
| 5-1        | USB power-saving function                    | Enabled                                                           | Disabled       | Off                    | ✓                          | ✓                       |
| 5-2        | Recovery conditions from receive buffer BUSY | 256 bytes free                                                    | 138 bytes free | Off                    | ✓                          | ✓                       |
| 5-3        | Paper sensor to output paper end signals     | Enabled both Roll paper end sensor and Roll paper near-end sensor | Disabled       | Off                    | ✓                          |                         |
| 5-4        | Error signal output                          | Enabled                                                           | Disabled       | Off                    | ✓                          | ✓                       |
| 5-5 to 5-8 | (Reserved)                                   | -                                                                 | -              | Off                    |                            |                         |

[Msw5-1]: Valid only when the USB interface communication condition of the built-in USB is set to the Vendor-defined class and the system configuration is set so that the USB driver can support the USB power-saving function.

[Msw5-2]: Valid only when the receive buffer capacity is 4 Kbytes.

[Msw5-4]: Valid only for parallel interface

*Msw7 (only for 4\*\* models)*

| <b>Msw</b> | <b>Function</b>                                                | <b>Off</b>                             | <b>On</b>                                           | <b>Initial setting</b> | <b>Msw Setting utility</b> | <b>Msw Setting Mode</b> |
|------------|----------------------------------------------------------------|----------------------------------------|-----------------------------------------------------|------------------------|----------------------------|-------------------------|
| 7-1        | Printer operation when print position misalignment is detected | Print starting position is not changed | Print starting position is adjusted (*1)            | Off                    | ✓                          | ✓                       |
| 7-2        | Printer operation in recovery from paper layout error          | Automatic paper layout measurement     | Paper feed to the next print starting position (*2) | Off                    | ✓                          | ✓                       |
| 7-3        | Autocut after closing cover                                    | Disabled                               | Enabled (*3)                                        | Off                    | ✓                          | ✓                       |
| 7-4        | Paper feed length after closing cover                          | 20 mm                                  | 40 mm                                               | Off                    | ✓                          | ✓                       |
| 7-5 to 7-8 | (Reserved)                                                     | -                                      | -                                                   | Off                    |                            |                         |

(\*1) When using label paper or paper with black mark, if print position misalignment is detected during reverse feeding, the printer feeds the paper to the next print starting position.

(\*2) When [Msw8-2] is OFF and the printer recovers from a paper layout error, the printer feeds the paper to the next print starting position.

(\*3) When using paper without black mark (excluding label roll paper), when the roll paper cover is closed, the printer feeds the paper for the amount set with [Msw7-4], and cuts the paper. After the power is turned on, if printing is executed for the first time after a cut command is executed, the printer starts printing after executing reverse feeding to the print starting position.

## Msw8

| Msw | Function                                                          | Off                                                     | On                              | Initial setting | Msw Setting utility | Msw Setting Mode |
|-----|-------------------------------------------------------------------|---------------------------------------------------------|---------------------------------|-----------------|---------------------|------------------|
| 8-1 | (Reserved)                                                        | -                                                       | -                               | Off             |                     |                  |
| 8-2 | User operation for recovery from paper layout error               | Send the error recovery command or open/close the cover | Send the error recovery command | Off             | ✓                   | ✓                |
| 8-3 | Paper out LED state in a paper near-end                           | LED On                                                  | LED Off                         | Off             | ✓                   | ✓                |
| 8-4 | Maximum length of automatic paper measurement                     | 160 mm                                                  | 300 mm                          | Off             | ✓                   | ✓                |
| 8-5 | Space insertion at left and right side of barcode print           | Disabled                                                | Enabled                         | Off             | ✓                   |                  |
| 8-6 | Paper feed to the print starting position when power is turned on | Enabled                                                 | Disabled                        | Off             | ✓                   | ✓                |
| 8-7 | (Reserved)                                                        | -                                                       | -                               | Off             |                     |                  |
| 8-8 | Printer cover open during operation                               | Automatic recoverable error                             | Recoverable error               | Off             | ✓                   | ✓                |

When [Msw 8-2] is Off, the paper layout is automatically measured and saved into the non-volatile memory of the printer after recovery from the error.

If [Msw8-2] is On, the printer paper layout is not changed after error recovery. If the correct paper is not inserted, the paper layout error will occur again.

The [Msw 8-4] setting influences initialization at power-on when “label paper” or “receipt paper with black mark” is specified for the paper layout. Refer to ["Setting Paper Layout" on page 57](#) for the paper layout.

When [Msw 8-6] is set to "Feeding paper to the print starting position at power on is disabled", the printer does not execute the operation of feeding paper to the print starting position at power on (the printer executes the operation when its cover is opened and closed). Hence, the user should note the following points since the printer operates on the assumption that the paper has already been fed to the print starting position at power on.

- a) Turn off the power supply after feeding of paper to the print starting position.
- b) Do not open the cover while power is off.
- c) If you have opened the cover while the power is off, open and close the cover once while the power is on to feed the paper to the print starting position.  
If printing is performed without the operation described above, the paper layout error (recoverable error) may occur. If the error occurs, recover from the error by the operation selected with [Msw8-2].

If the print starting position has not been set at power-on, the printing position of the first sheet may shift, or a paper layout error may occur.

## Customized values

| Item                                                       | Option<br>( <u>underlined: initial setting</u> )                                                                                                                                                                                                          | Msw<br>Setting<br>utility | Msw<br>Setting<br>Mode |
|------------------------------------------------------------|-----------------------------------------------------------------------------------------------------------------------------------------------------------------------------------------------------------------------------------------------------------|---------------------------|------------------------|
| NV user memory capacity                                    | <u>1 KB</u> , 64 KB, 128 KB, 192 KB                                                                                                                                                                                                                       | ✓                         |                        |
| NV graphics memory capacity                                | None, 64 KB, 128 KB, 192 KB, 256 KB, 320 KB,<br><u>384 KB</u>                                                                                                                                                                                             | ✓                         |                        |
| Print density                                              | 70%, 75%, 80%, 85%, 90%, 95%, 100%, 105%,<br><u>110%</u> , 115%, 120%, 125%, 130%, 135%, 140%                                                                                                                                                             | ✓                         | ✓                      |
| Print speed                                                | Level 1 (Slow) - <u>Level 6</u> - Level 9 (Fast)                                                                                                                                                                                                          | ✓                         | ✓ <sup>*1</sup>        |
| Default character code table <sup>*1</sup>                 | Initial setting: <u>Page 0: PC437 (USA, Standard<br/>Europe)</u>                                                                                                                                                                                          | ✓                         | ✓                      |
| Default international character <sup>*1</sup>              | Initial setting: <u>USA</u>                                                                                                                                                                                                                               | ✓                         | ✓                      |
| Selection of the interface <sup>*1</sup>                   | <u>Auto</u> , UIB, Built-in USB                                                                                                                                                                                                                           | ✓                         | ✓                      |
| Number of divisions of thermal head energizing             | <u>1</u> , 2, 3, 4                                                                                                                                                                                                                                        | ✓                         |                        |
| Automatic replacement of Font A <sup>*1</sup>              | <u>Do not replace</u> , Font B                                                                                                                                                                                                                            | ✓                         | ✓                      |
| Automatic replacement of Font B <sup>*1</sup>              | <u>Do not replace</u> , Font A                                                                                                                                                                                                                            | ✓                         | ✓                      |
| Paper selection<br>(monochrome or two-color) <sup>*2</sup> | <u>Monochrome</u> , two-color                                                                                                                                                                                                                             | ✓                         | ✓                      |
| Paper width                                                | 38 mm - <u>80 mm</u> (1 mm pitches)                                                                                                                                                                                                                       | ✓                         | ✓ <sup>*3</sup>        |
| Black-color density in two-color printing <sup>*2</sup>    | Light, <u>Medium</u> , Dark                                                                                                                                                                                                                               | ✓                         |                        |
| Buzzer control <sup>*1</sup>                               | Buzzer selection: Internal, Option, Disable<br>Buzzer frequency: Continuous, 1 time, No sound<br>Sound pattern: Pattern A, B, C, D, or E<br>(Refer to " <a href="#">Setting items of TM-L90 4** models</a> "<br>on page 119, about the initial settings.) | ✓                         | ✓                      |

\*1: Not available for TM-L90 other than 4\*\* models

\*2: Not available for TM-L90 4\*\* models

\*3: Selectable 38, 58, 60, 70, 80 mm only



### Note:

- The maximum print speed is available for only the one-part energizing mode. However, if the print duty is too high in the one-part energizing mode, the printer will automatically reduce the printing speed.
- The four-part energizing mode reduces power consumption.
- The print width can be set in 43 ways with 1 mm pitches in the range from 38 mm to 80 mm. However, it cannot be set in the range from 71 mm to 79 mm.

- Depending on the paper type, it is recommended to set the print density as shown in the table below for the best print quality.

|         | Paper type      | Density level |
|---------|-----------------|---------------|
| Receipt | P35024          | 90%           |
|         | KF50            | 95%           |
|         | F5041(55)       | 100%          |
| Label   | 150PSMW         | 120%          |
|         | DTM9502, KL80GT | 130%          |

Serial communication conditions

| Item         | Option<br>( <u>underlined: initial setting</u> )             | Msw Setting<br>utility | Msw Setting<br>Mode |
|--------------|--------------------------------------------------------------|------------------------|---------------------|
| Baud rate    | 2400, 4800, 9600, <u>19200</u> , 38400, 57600,<br>115200 bps | ✓                      | ✓                   |
| Parity       | <u>None</u> , Odd, Even                                      | ✓                      | ✓                   |
| Flow control | <u>DTR/DSR</u> , XON/XOFF                                    | ✓                      | ✓                   |
| Data length  | 7-bits, <u>8-bits</u>                                        | ✓                      | ✓                   |



**Note:**

For models other than 4\*\* models, these settings are valid only when the DIP switch 1-2 is Off.

USB communication conditions (only for 4\*\* models)

This setting is valid for the built-in USB.

| Item  | Option<br>( <u>underlined: initial setting</u> ) | Msw Setting<br>utility | Msw Setting<br>Mode |
|-------|--------------------------------------------------|------------------------|---------------------|
| Class | <u>Vendor-defined class</u> , Printer class      | ✓                      | ✓                   |

## 2.8.2 Memory switches of TM-L90 Peeler Model

In the following tables, “✓” shows that the setting can be set by the utility or the setting mode.

### Msw1

| Msw | Function                          | Off                            | On                  | Initial setting | Msw Setting utility | Msw Setting Mode |
|-----|-----------------------------------|--------------------------------|---------------------|-----------------|---------------------|------------------|
| 1-1 | Transmission of Power-on notice   | Disabled                       | Enabled             | Off             | ✓                   | ✓                |
| 1-2 | Receive buffer capacity           | 4 Kbytes                       | 45 bytes            | Off             | ✓                   | ✓                |
| 1-3 | BUSY condition                    | Receive buffer full or Offline | Receive buffer full | Off             | ✓                   | ✓                |
| 1-4 | Data processing for receive error | Replaced with "?"              | Ignored             | Off             | ✓                   | ✓                |
| 1-5 | Automatic line feed               | Disabled                       | Enabled             | Off             | ✓                   | ✓                |
| 1-6 | (Reserved)                        | Fixed to Off                   |                     | Off             |                     |                  |
| 1-7 | #6 pin of RS-232                  | Not used                       | Used for reset      | Off             | ✓                   | ✓                |
| 1-8 | #25 pin of RS-232                 | Not used                       | Used for reset      | Off             | ✓                   | ✓                |

[Msw1-4], [Msw1-7], [Msw1-8]: Valid only for serial interface

[Msw1-5]: Valid only for parallel interface

[Msw1-7], [Msw1-8]: Not available for TM-L90 Peeler 39\* models

### Msw5 (only for 39\* models)

| Msw        | Function                                     | Off                                                               | On             | Initial setting | Msw Setting utility | Msw Setting Mode |
|------------|----------------------------------------------|-------------------------------------------------------------------|----------------|-----------------|---------------------|------------------|
| 5-1        | USB power-saving function                    | Enabled                                                           | Disabled       | Off             | ✓                   | ✓                |
| 5-2        | Recovery conditions from receive buffer BUSY | 256 bytes free                                                    | 138 bytes free | Off             | ✓                   | ✓                |
| 5-3        | Paper sensor to output paper end signals     | Enabled both Roll paper end sensor and Roll paper near-end sensor | Disabled       | Off             | ✓                   |                  |
| 5-4        | Error signal output                          | Enabled                                                           | Disabled       | Off             | ✓                   | ✓                |
| 5-5 to 5-8 | (Reserved)                                   | -                                                                 | -              | Off             |                     |                  |

[Msw5-1]: Valid only when the USB interface communication condition of the built-in USB is set to the Vendor-defined class and the system configuration is set so that the USB driver can support the USB power-saving function.

[Msw5-2]: Valid only when the receive buffer capacity is 4 Kbytes.

[Msw5-4]: Valid only for parallel interface

Msw7 (only for 39\* models)

| Msw        | Function                             | Off                                      | On                                  | Initial setting | Msw Setting utility | Msw Setting Mode |
|------------|--------------------------------------|------------------------------------------|-------------------------------------|-----------------|---------------------|------------------|
| 7-1 to 7-7 | (Reserved)                           | -                                        | -                                   | Off             |                     |                  |
| 7-8        | Function when FEED button is pressed | Feed to the next print starting position | Feed to the manual cutting position | Off             | ✓                   | ✓                |

[Msw7-8] is enabled only in the continuous issuing mode.

When [Msw7-8] is Off, the printer feeds paper to the next print starting position, if the FEED button is pressed.

When [Msw7-8] is On, if you press the FEED button once, the printer feeds one piece of the label to the manual cutting position. Then if you press the FEED button again, the printer feeds the next label to the print starting position. By pressing the FEED button repeatedly, the operation described above is repeated.

Msw8

| Msw | Function                                                          | Off                                                     | On                                       | Initial setting | Msw Setting utility | Msw Setting Mode |
|-----|-------------------------------------------------------------------|---------------------------------------------------------|------------------------------------------|-----------------|---------------------|------------------|
| 8-1 | User operation for recovery from paper layout error               | Recovers by pressing FEED button                        | Does not recover by pressing FEED button | Off             | ✓                   | ✓                |
| 8-2 | User operation for recovery from paper layout error               | Send the error recovery command or open/close the cover | Send the error recovery command          | Off             | ✓                   | ✓                |
| 8-3 | Paper out LED state in a paper near-end                           | LED On                                                  | LED Off                                  | Off             | ✓                   | ✓                |
| 8-4 | Maximum length of automatic paper measurement                     | 160 mm                                                  | 300 mm                                   | Off             | ✓                   | ✓                |
| 8-5 | Space insertion at left and right side of barcode print           | Disabled                                                | Enabled                                  | Off             | ✓                   |                  |
| 8-6 | Paper feed to the print starting position when power is turned on | Enabled                                                 | Disabled                                 | Off             | ✓                   | ✓                |
| 8-7 | (Reserved)                                                        | -                                                       | -                                        | Off             |                     |                  |
| 8-8 | Printer cover open during operation                               | Automatic recoverable error                             | Recoverable error                        | Off             | ✓                   |                  |

If [Msw8-1] is OFF, the paper is determined automatically if the printer recovers from the paper layout error.

Furthermore, the results of automatic paper determination are overwritten if the settings for paper layout are already saved in the NV memory.

If [Msw8-2] is OFF, the paper is determined automatically if the printer recovers from the paper layout error.

Furthermore, the results of automatic paper determination are overwritten if the settings for paper layout are already saved in the NV memory.

The [Msw 8-4] setting influences the amount of paper fed when the power is turned on or the cover is opened/closed if the paper layout is not set. Refer to "[Setting Paper Layout](#)" on page 57 for the paper layout.

When [Msw 8-6] is set to "Feeding paper to the print starting position at power on is disabled", the printer does not execute the operation of feeding paper to the print starting position at power on (the printer executes the operation when its cover is opened and closed). Hence, the user should note the following points since the printer operates on the assumption that the paper has already been fed to the print starting position at power on.

- a) Turn off the power supply after feeding of paper to the print starting position.
- b) Do not open the cover while power is off.
- c) If you have opened the cover while the power is off, load the paper in the paper path (peeler or continuous issuing) while the power is on, and then press the FEED button to initialize the mechanism (paper feeding operation).  
If printing is performed without the operation described above, the paper layout error (recoverable error) may occur. If the error occurs, recover from the error by the operation selected with [Msw8-1] or [Msw8-2].

Customized values

| Item                                                       | Option<br>( <u>underlined</u> : initial setting)                                              | Msw<br>Setting<br>utility | Msw<br>Setting<br>Mode |
|------------------------------------------------------------|-----------------------------------------------------------------------------------------------|---------------------------|------------------------|
| NV user memory capacity                                    | <u>1 KB</u> , 64 KB, 128 KB, 192 KB                                                           | ✓                         |                        |
| NV graphics memory capacity                                | None, 64 KB, 128 KB, 192 KB, 256 KB, 320 KB,<br><u>384 KB</u>                                 | ✓                         |                        |
| Print density                                              | 70%, 75%, 80%, 85%, 90%, 95%, 100%, 105%,<br><u>110%</u> , 115%, 120%, 125%, 130%, 135%, 140% | ✓                         | ✓                      |
| Print speed                                                | Level 1 (Slow) - <u>Level 6</u> - Level 9 (Fast)                                              | ✓                         | ✓ <sup>*1</sup>        |
| Default character code table <sup>*1</sup>                 | Initial setting: <u>Page 0: PC437 (USA, Standard<br/>Europe)</u>                              | ✓                         | ✓                      |
| Default international character <sup>*1</sup>              | Initial setting: <u>USA</u>                                                                   | ✓                         | ✓                      |
| Number of divisions of thermal<br>head energizing          | <u>1</u> , 2, 3, 4                                                                            | ✓                         |                        |
| Paper selection (monochrome or<br>two-color) <sup>*2</sup> | <u>Monochrome</u> , two-color                                                                 | ✓                         | ✓                      |
| Paper width                                                | 38 mm - <u>80 mm</u> (1 mm pitches)                                                           | ✓                         | ✓ <sup>*3</sup>        |
| Black-color density in two-color<br>printing <sup>*2</sup> | Light, <u>Medium</u> , Dark                                                                   | ✓                         |                        |

\*1: Not available for TM-L90 Peeler other than 39\* models

\*2: Not available for TM-L90 Peeler 39\* models

\*3: Selectable 38, 58, 60, 70, 80 mm only



**Note:**

- ❑ *The maximum print speed is available for only the one-part energizing mode. However, if the print duty is too high in the one-part energizing mode, the printer will automatically reduce the printing speed.*
- ❑ *The four-part energizing mode reduces power consumption.*
- ❑ *The print width can be set in 43 ways with 1 mm pitches in the range from 38 mm to 80 mm. However, it cannot be set in the range from 71 mm to 79 mm.*
- ❑ *Depending on the paper type, it is recommended to set the print density as shown in the table below for the best print quality.*

|         | Paper type | Density level |
|---------|------------|---------------|
| Receipt | P35024     | 90%           |
|         | KF50       | 95%           |
|         | F5041(55)  | 100%          |
| Label   | KL80GT     | 130%          |

Serial communication conditions

| Item         | Option<br>( <u>underlined: initial setting</u> )             | Msw Setting<br>utility | Msw Setting<br>Mode |
|--------------|--------------------------------------------------------------|------------------------|---------------------|
| Baud rate    | 2400, 4800, 9600, <u>19200</u> , 38400, 57600,<br>115200 bps | ✓                      | ✓                   |
| Parity       | <u>None</u> , Odd, Even                                      | ✓                      | ✓                   |
| Flow control | <u>DTR/DSR</u> , XON/XOFF                                    | ✓                      | ✓                   |
| Data length  | 7-bits, <u>8-bits</u>                                        | ✓                      | ✓                   |



**Note:**

For models other than 4\*\* models, these settings are valid only when the DIP switch 1-2 is Off.

USB communication conditions (only for 39\* models)

This setting is valid for the built-in USB.

| Item  | Option<br>( <u>underlined: initial setting</u> ) | Msw Setting<br>utility | Msw Setting<br>Mode |
|-------|--------------------------------------------------|------------------------|---------------------|
| Class | <u>Vendor-defined class</u> , Printer class      | ✓                      | ✓                   |

## 2.9 Paper Loading Method

### **WARNING:**

Do not open the roll paper cover (for the TM-L90 Peeler Model, do not open the peeler cover and the roll paper cover) during the operation. Doing so may damage the printer.

Do not touch the manual cutter with your hands when installing or replacing roll paper. Touching the manual cutter may result in injury.

For the TM-L90, when the printer is placed horizontally, the raised roll paper cover may close suddenly depending on the inclining angle of the printer. Take care not to get your finger caught in it.

#### **Note:**

Be sure to use roll paper that meet the specifications.

### 2.9.1 With TM-L90

1. Open the roll paper cover, using the cover open lever.
2. Pull out roll paper with little paper remaining and insert new roll paper, aligning the paper with the guide, as shown below.

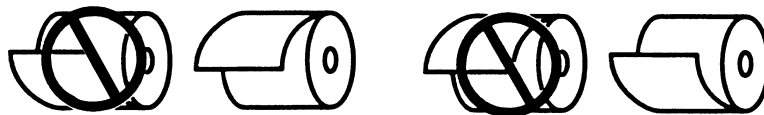
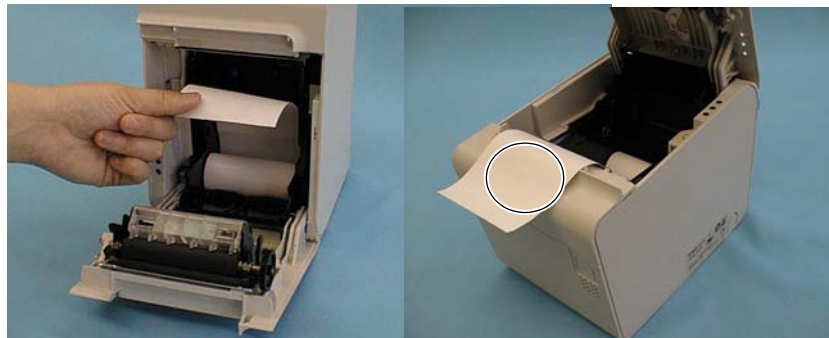

3. Close the roll paper cover; then cut off the paper with the manual cutter.

### **WARNING:**

Be careful that your finger is not inside the printer when you close the cover because you can get your finger caught inside.

### 2.9.2 With the TM-L90 Peeler Model

With the TM-L90 Peeler, the paper loading method differs depending on whether peeling issuing or continuous issuing is used. They are explained as follows.

#### *Paper setting with peeling issuing*

1. Pull the peeler open lever forward, and open the peeler cover.
2. Pull the cover open lever, and open the roll paper cover.
3. If there is a roll paper with little paper remaining inside the printer, take it out.
4. Check that the printer is on. If it is not on, turn it on.
5. Put a new roll paper in the printer. Make sure that the roll paper is oriented as shown in the following figure.

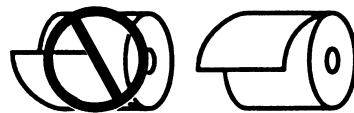
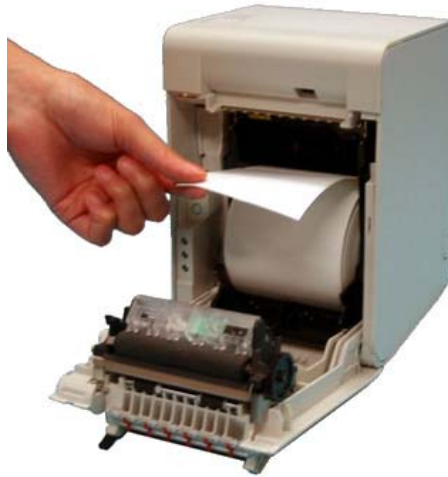

6. Slide the mode switch to the right (peeling issuing mode).



7. As shown in the following figure, pull the end of the paper to the bottom of the square hole above the manual cutter (label peeling sensor), and close the roll paper cover.



**Note:**

*Matching the leading edge of the roll paper with the printed marks on the printer ensures that the fewest possible labels are ejected automatically.*



**WARNING:**

*Do not close the roll paper cover with your finger still inside the roll paper cover. Doing so may lead to injury.*

8. A few labels are fed automatically and the PAPER OUT LED starts flashing.
9. Pass the backing paper that you pulled out to the other side of the peeler cover as shown in the following figure, and close the peeler cover.



10. Press the FEED button. The printer automatically feeds the paper to the start position, and the PAPER OUT LED goes off.



**Note:**

*If the paper is not set properly when the FEED button is pressed, there may be label adhesive on the rollers of the peeler. Peel off one label, and remove the adhesive from the roller by lifting it off with the adhesive side of the label. For the cleaning method, refer to [page 107](#). Paper setting with continuous issuing (not using the peeler)*

*Paper setting with continuous issuing*

1. Pull the peeler open lever forward, and open the peeler cover.
2. Pull the cover open lever, and open the roll paper cover.
3. If there is roll paper with little paper remaining inside the printer, take it out.
4. Put new roll paper in the printer as shown in the following figure.

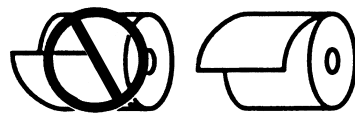

5. Slide the mode switch to the left (continuous issuing mode).



6. As shown in the following figure, pull the end of the paper to the bottom of the square hole above the manual cutter (label peeling sensor).



**Note:**

Matching the leading edge of the roll paper with the printed marks on the printer ensures that the fewest possible labels are ejected automatically.

7. Pressing down the end of the paper, close the roll paper cover. The printer automatically feeds the paper to the start position.



**WARNING:**

Do not close the roll paper cover with your finger still inside the roll paper cover. Doing so may lead to injury.

8. Close the peeler cover and cut off the excess paper with the manual cutter.

### 2.9.3 Setting Paper Layout

Before printing, it is necessary to set the layout information for paper type and size in the printer. Doing paper feeding or printing without this layout setting may result in a paper out (no paper left) or an error. In all of the following cases, therefore, make layout settings before use.

- When using label paper for the first time (except when replacing label paper of the same type)
- When you change the paper type (full-surface label paper/receipt paper, label paper, receipt paper with black mark)
- When changing the size of the label paper
- When you change the liner for one of different transmittance.

There are automatic and manual layout settings. The setting procedure is as follows.

If you use the printer without making a layout setting and a paper out (no paper left) or an error occurs as a result (refer to [page 110](#)), opening and closing the cover automatically sets a new layout.



**Note:**

*The above automatic layout setting by opening and closing the cover is available with firmware version 1.05 or later. It enables you to make layout setting by intentionally generating an error in paper feeding on printing. This function can be turned off using the Memory Switch Setting Utility.*

### Automatic paper layout setting

Automatic paper layout setting sets a paper layout on the basis of the black mark or label position detected by the printer.

This method is available for label paper, receipt paper, and receipt paper with black mark.



**Note:**

*When using label paper with black mark, it is necessary to make manual setting of paper layout (set using the Memory Switch Setting Utility or ESC/POS command).*

This automatic paper layout setting can be used with any of the following three methods.

- Use the automatic paper layout setting mode provided for the printer.
- Use the Memory Switch Setting Utility.
- Directly control the printer using ESC/POS commands.



**Note:**

*For the Memory Switch Setting Utility and ESC/POS commands, refer to "[Introduction of Control Methods](#)" on page 83.*

*When using Advanced Printer Driver (APD) or ESC/POS commands, set the print area as required. The print area position influences the paper layout.*

Described below is a procedure for automatic setting of paper layout that allows you to independently set the paper layout on the printer.

It is also possible to cause an error intentionally so that the printer will feed several labels and remember the label paper size. See the instructions below.

- ❑ TM-L90 setting procedure (Procedure for setting the paper type and size to the printer)
  1. Install the printer.
  2. Connect the power and other cables.
  3. Open the roll paper cover.
  4. Set the roll paper in the printer.

5. With the roll paper cover open, turn on the power while pressing the FEED button inside the printer.  
(Keep pressing the FEED button until the ERROR LED comes on.)
6. Check that the ERROR LED is on, and release the FEED button.
7. Press the FEED button 6 times.
8. Then, close the roll paper cover.  
The printer feeds several labels and remembers the label paper size. This completes the task.

□ TM-L90 Peeler Model setting procedure (procedure for setting the paper type and size in the printer)

There are the following 2 cases.

<When the power is off>

1. Open the peeler cover.
2. Open the roll paper cover.
3. Set the roll paper in the printer.
4. With the roll paper cover open, turn on the power while pressing the FEED button inside the printer.  
(Keep pressing the FEED button until the ERROR LED comes on.)
5. Check that the ERROR LED is on, and release the FEED button.
6. Press the FEED button 6 times.
7. For peeling issuing, set the end of the roll paper in the peeler, and for continuous issuing, set it in the ejection path, and close the roll paper cover. The printer feeds several labels and remembers the label paper size. This completes the task.
8. For peeling issuing, after setting the paper, the PAPER OUT LED flashes. To print, insert the label into the peeler path, and press the FEED button.

<When the power is on>

1. Open the peeler cover.
2. Open the roll paper cover.
3. With the roll paper cover open, press the FEED button inside the printer.
4. Close the roll paper cover.  
The PAPER OUT LED flashes.
5. For peeling issuing, set the end of the roll paper in the peeler, and for continuous issuing, set it in the ejection path, and close the roll paper cover. The printer feeds several labels and remembers the label paper size. This completes the task.

6. For peeling issuing, after setting the paper, the PAPER OUT LED flashes. To print, insert the label into the peeler path, and press the FEED button.

If an error occurs without completing the setting, turn the power off, and repeat the operation from step 3.

The automatic paper layout value is set according to the following expression.

- |     |                                                                                                              |
|-----|--------------------------------------------------------------------------------------------------------------|
| L3: | $(L2 + 1.5)$ mm:                                                                                             |
| L4: | $(L2 \times 2/5)$ mm:                                                                                        |
| L5: | $(L1-L2-3)$ mm                                                                                               |
| L6: | 4.7 mm (fixed value)                                                                                         |
| L7: | When the liner width is 78 mm or more: 70 mm<br>When the liner width is less than 78 mm: (Liner width -8) mm |



**Note:**

L1 and L2 are measured by the printer. See the following sketch for the lengths L1 to L7.

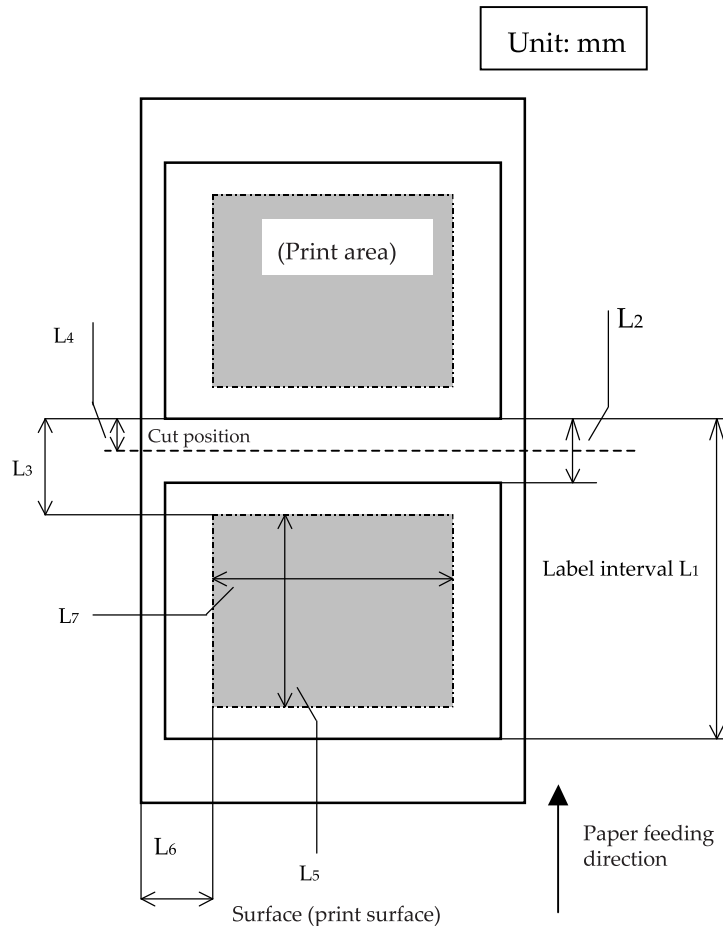

Parameters Calculated for Automatic Layout Setting

❑ Manual paper layout setting

Manual paper layout setting is to directly enter paper data into the non-volatile memory of the printer to execute the "paper layout setting" function. As compared to automatic setting, manual setting enables finer adjustment of the paper layout. You can set the paper type, mark-to-mark distance, mark length, paper width and print area.

This "manual paper layout setting" can be used in either of the following two methods. Refer to the corresponding manuals for how to use these methods.

- Use the Memory Switch Setting Utility.  
(Manual: Memory Switch Setting Utility, User's Manual)
- Directly control the printer using ESC/POS commands.  
(Manual: ESC/POS Command Reference  
For details on how to obtain this manual, see ["Introduction of Control Methods" on page 83](#)).



**Note:**

For the Memory Switch Setting Utility and ESC/POS commands, refer to ["Introduction of Control Methods" on page 83](#).

When using the Advanced Printer Driver (APD) or ESC/POS commands, set the print area as required. The print area position influences the paper layout. When using label paper with black mark, always make a manual setting of paper layout.

## 2.9.4 Clearing Paper Layout Setting

This printer has a function to reset the paper layout set in the automatic paper layout setting mode or by manual setting to the factory setting.



**Note:**

This function may be unavailable depending on when you purchased your printer. You cannot use this function if the firmware version of the printer printed in a self test (["Memory Switch Settings" on page 42](#)) is 1.04 or earlier. For more information, please contact your sales representative.

The method of clearing the paper layout settings in the printer is as follows.

1. Open the peeler cover.
2. Open the roll paper cover.
3. Load roll paper.
4. Until the ERROR LED is on, hold down the FEED button (on the inside of the roll paper cover: see [page 42](#)) and turn on the power supply.
5. When the ERROR LED comes on, release the FEED button (inside the roll paper cover).
6. Press the FEED button 4 times.
7. Close the roll paper cover.  
The paper information in the NV memory in the printer is cleared, and to indicate that the layout information is cleared, the printer automatically feeds paper.

## Chapter 3

# Connecting to the Host Computer and Options

### 3.1 Connecting the Cable

This printer has 5 types of interface, serial, parallel, USB, Ethernet, and wireless LAN. The method of connecting such options as a customer display varies depending on the interface type. Note that some interfaces do not accept specific connection methods.

All cables are connected to the connector panel located on the lower rear side of the printer.

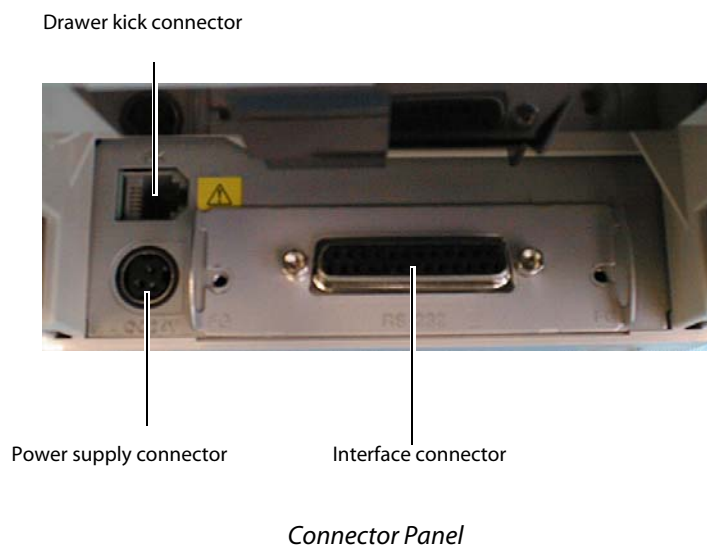

**Note:**

The figure above shows the connector panel for RS-232 interface model printer (TM-L90 other than 4\*\* models, TM-L90 Peeler other than 39\* models). The shape of the interface connector varies according to the type of interface used.

Be sure to turn off the power supply for both the printer and the host computer unit before connecting the various cables.

Be sure to unplug the power cord before inserting or removing the interface board.

## 3.2 Connecting to the Host Computer

### 3.2.1 With the RS-232C Interface

When the TM printer is connected to a host PC with a serial interface, the following connection forms are possible:

- Stand alone
- Pass-through

Connections of available serial cross cables are as follows:

Type A

| D-Sub 25P(TM) |        |  | D-Sub 9P(PC) |        |
|---------------|--------|--|--------------|--------|
| Pin No        | Signal |  | Signal       | Pin No |
| 1             | FG     |  | DCD          | 1      |
| 2             | TXD    |  | TXD          | 3      |
| 3             | RXD    |  | RXD          | 2      |
| 20            | DTR    |  | DTR          | 4      |
| 6             | DSR    |  | DSR          | 6      |
| 4             | RTS    |  | RTS          | 7      |
| 5             | CTS    |  | CTS          | 8      |
| 7             | GD     |  | GD           | 5      |
| 25            | RESET  |  | RI/RESET     | 9      |

Type B

| D-Sub 25P(TM) |        |  | D-Sub 9P(PC) |        |
|---------------|--------|--|--------------|--------|
| Pin No        | Signal |  | Signal       | Pin No |
| 1             | FG     |  | DCD          | 1      |
| 2             | TXD    |  | TXD          | 3      |
| 3             | RXD    |  | RXD          | 2      |
| 20            | DTR    |  | DTR          | 4      |
| 6             | DSR    |  | DSR          | 6      |
| 4             | RTS    |  | RTS          | 7      |
| 5             | CTS    |  | CTS          | 8      |
| 7             | GD     |  | GD           | 5      |
| 25            | RESET  |  | RI/RESET     | 9      |

The types of cable (Type A or B) varies depending on the combination of the operation method and the handshake for the TM printer. You can operate the TM printer by a Windows driver, OPOS, or ESC/POS commands. Xon/Xoff, DTR/DSR or RTS/CTS are available as handshake control. See tables in the following sections for the cable type for each connection.



**Note:**

Refer to [Chapter 5](#) for the Windows driver, OPOS ADK, and ESC/POS commands. Refer to ["Connecting the Cable"](#) on page 63 for the cable connection procedure.

DTR/DSR control is available for OPOS.

Xon/Xoff or CTS/RTS control is available for APD. When using APD in serial connection, read the Note in ["EPSON Advanced Printer Driver Support Environment"](#) on page 85 that contains precautions for TrueType font printing.

**Direct Connection (Stand alone)**

Both TM printer and DM-D are connected to the host PC directly via serial port or USB port. The following table shows the application control and cable connection types.

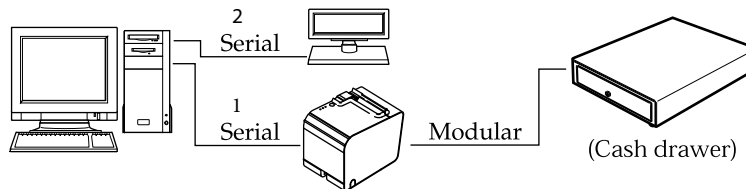

| Application control     |   | Xon/Xoff (except OPOS)                     | DTR/DSR (DOS, Windows (only OPOS)) | RTS/CTR (DOS, Windows (hardware control: Windows driver)) |
|-------------------------|---|--------------------------------------------|------------------------------------|-----------------------------------------------------------|
| TM side control setting |   |                                            |                                    |                                                           |
| Xon/Xoff                | 1 | Type A or B                                | —                                  | —                                                         |
|                         | 2 | DM-D500: A, B<br>Other DM-D: not available | —                                  | —                                                         |
| DTR/DSR                 | 1 | —                                          | Type A or B                        | Type B                                                    |
|                         | 2 | —                                          | Type A or B                        | Type B                                                    |

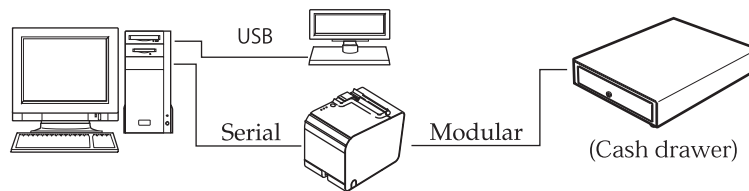

### Pass-through Connections

TM printer is connected to DM-D via serial port and DM-D is connected to the host PC via serial port. The following table shows the application control and cable connection types.

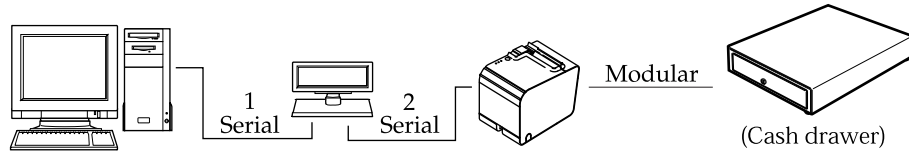

| Application control<br>TM side control setting |   | Xon/Xoff<br>(except OPOS) | DTR/DSR<br>(DOS, Windows<br>(only OPOS)) | RTS/CTR<br>(DOS, Windows (hardware control:<br>Windows driver)) |
|------------------------------------------------|---|---------------------------|------------------------------------------|-----------------------------------------------------------------|
| Xon/Xoff                                       |   | Not available             | —                                        | —                                                               |
| DTR/DSR                                        | 1 | —                         | Type A or B                              | Type B                                                          |
|                                                | 2 | —                         | Type A or B                              | Type A or B                                                     |

### Connection procedure

1. Press the connector on the end of the interface cable firmly onto the interface connector located on the connector panel.
2. When using connectors equipped with screws, use the screws to tighten the connectors firmly in place.

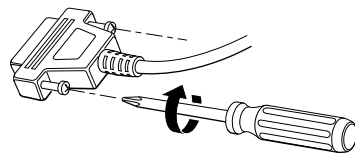

*Tightening Screws*

3. For interface cables equipped with a ground line, attach the ground line to the screw hole marked "FG" on the printer.
4. Connect the other end of the interface cable to the host computer.

### 3.2.2 With the Parallel (IEEE1284) Interface

TM printer is connected to the host PC via parallel port mounting parallel interface board (UB-P\*\*). DM-D is connected to the host PC via serial port or USB port.

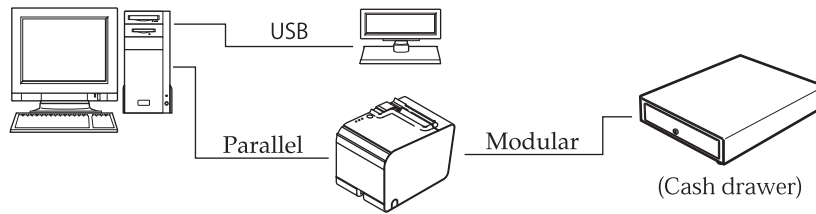
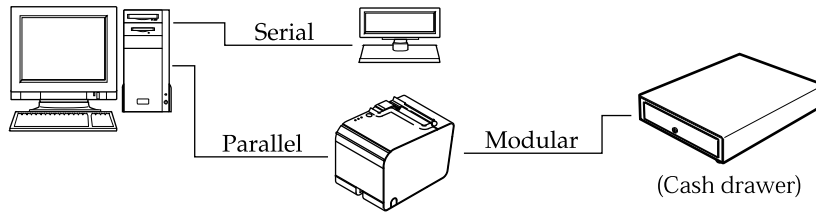

### Connection procedure

1. Press the connector on the end of the interface cable firmly onto the interface connector located on the connector panel.
2. Press down the clips on either side of the connector to lock it in place.
3. For interface cables equipped with a ground line, attach the ground line to the screw hole marked "FG" on the printer.
4. Connect the other end of the interface cable to the host computer.

### 3.2.3 With the USB Interface

A USB interface TM printer is connected to the host PC via USB. The second TM printer can be connected via a self-powered USB hub from the printer connected to the host PC.

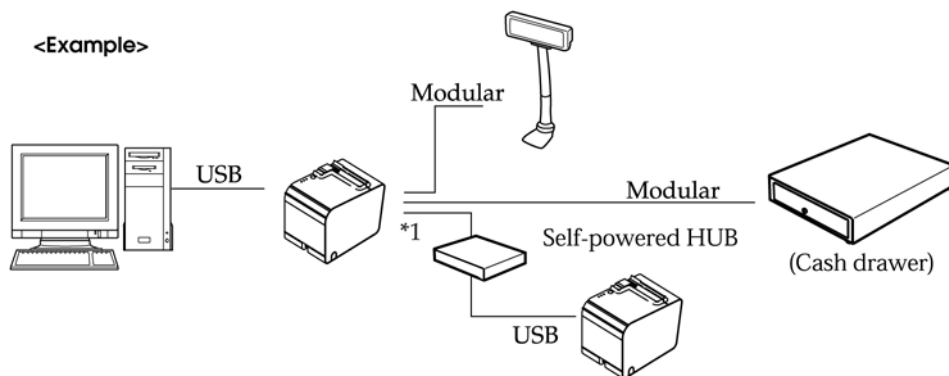

- \*1 Only the printer with the USB hub function allows another TM printer to be connected using a USB cable.
- \*2 Epson does not supply the port driver or similar program necessary to control the USB interface printer with the ESC/POS commands. Control it with the driver (APD, OPOS).

### Connection procedure

1. Attach the locking wire saddle at the location shown in figure below.
2. Hook the USB cable through the locking wire saddle as shown in the figure below.



**Note:**

Hooking the USB cable through the locking wire saddle as shown in figure below will prevent the cable from coming unplugged.

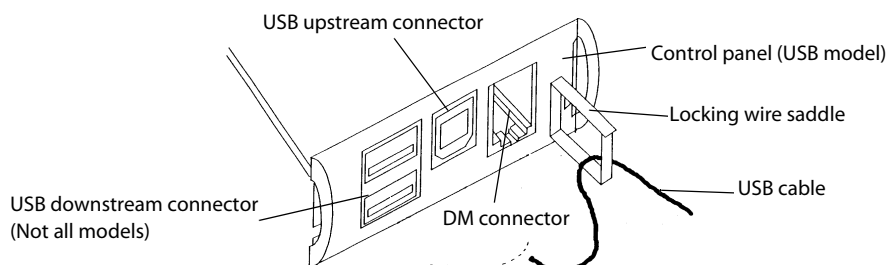

*Attaching Locking Wire Saddle*

3. Connect the USB cable from the host computer to the USB upstream connector.
4. For models that have the UB-U\*\* installed, a maximum of two USB devices can be connected to the USB downstream connector.



**Note:**

The hub installed in the USB model's control panel is a bus power-supply hub. Therefore, it is important to note that bus power supply hubs (including other USB models) and bus power supply functions with 100 mA or more consumption current cannot be connected directly to the printer.



**Note:**

To use USB model TM printer, you need to install the USB device driver on host computer after connecting TM printer to the host computer. For information on how to obtain the required device drivers and their installation procedures, contact Epson or your dealer.



**Note:**

The connector panel varies depending on the models.

If you connect a customer display (DM-D), set the DIP switch settings as follows. For details, see the User's Manual packed with your customer display.



**Note:**

TM-L90 other than 4\*\* models or TM-L90 Peeler other than 39\* models have the DIP switches. TM-L90 4\*\* models or TM-L90 Peeler 39\* models do not have the DIP switches; however, various functions can be set with memory switches. For detailed information about the memory switches, see ["Memory Switch Settings" on page 42](#).

| Item                 | Selection          |           |
|----------------------|--------------------|-----------|
| Transmission setting | Transmission speed | 19200 bps |
|                      | Parity             | None      |
|                      | Data word length   | 8 bits    |

Before turning on the printer, be sure to turn on the customer display (DM-D). If you reverse the order, the customer display will not be recognized correctly.

To satisfy the EMI standard, be sure to mount the ferrite core on the display module cable. To mount the ferrite core, put the display module cable into the ferrite core.

### 3.2.4 With the Ethernet Interface (TM-L90 only)

TM printer with the Ethernet interface is connected to a network with the Ethernet cable via a Hub.

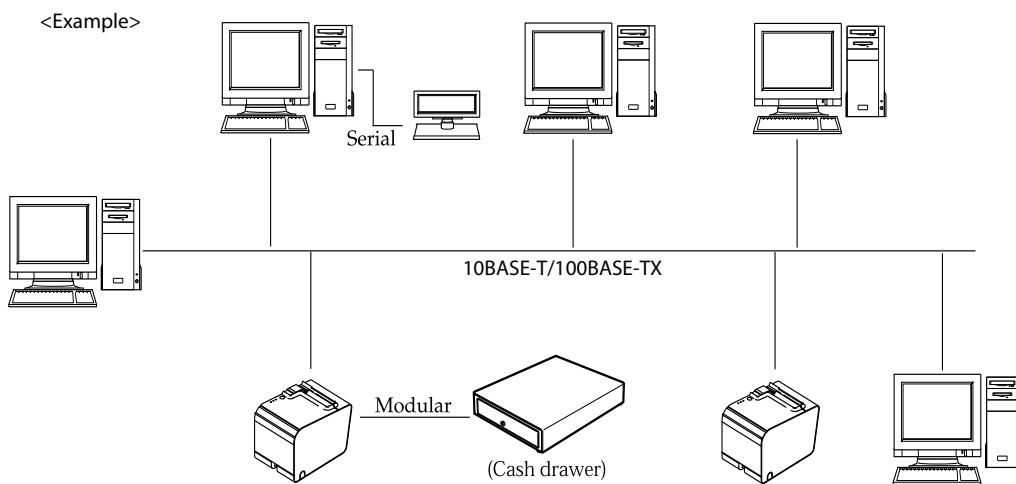

**Note:**

The Ethernet interface TM printer does not accept a customer display (DM-D). Connect the customer display to a POS terminal or appropriate equipment other than the printer.



**Note:**

When controlling the printer with OPOS, it is necessary to use exclusive control. Therefore, when using 1 printer with several PCs, it is necessary to take into account application programming whereby a PC that already has the exclusive right must release it, then another PC must claim it.

Connection procedure

**⚠ CAUTION:**

Connecting devices directly to LAN cables that are installed outdoors will expose them to damage from power surges caused by lightning and other inductive sources. It is best to make sure that devices without proper surge protection are cushioned by being connected through devices that do have surge protection. Otherwise, it is better not to connect them to outdoor lines.

Never attempt to connect the customer display cable, drawer kick cable or the standard telephone line cable to the 10BASE-T/100BASE-TX Ethernet connector.

1. Confirm that the power supplies for both the printer and the host computer have been turned off.
2. Connect the 10BASE-T/100BASE-TX cable to the 10BASE-T/100BASE-TX Ethernet connector by pressing firmly until the connectors click.

**✎ Note:**

For the various methods of setting the Ethernet interface, refer to the Technical Reference Guide for the Ethernet interface board.

**3.2.5 With the Wireless LAN Interface**

For details on how to set up a wireless LAN interface, see the Technical Reference Guide for the interface board or the wireless LAN interface unit.

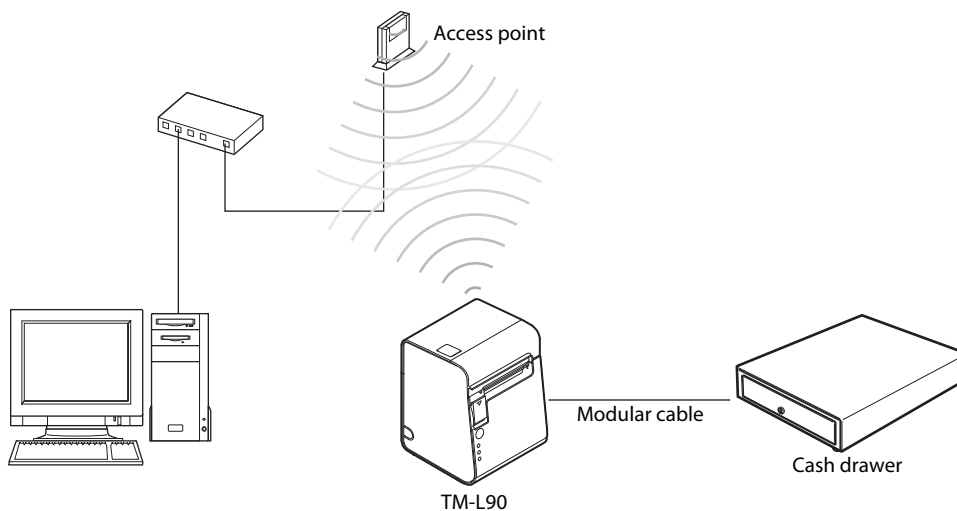

### 3.3 Connecting the Cash Drawer

#### **CAUTION:**

- Specifications of drawers differ depending on makers or models. When you use a drawer other than specified, make sure its specification meets the following conditions. Otherwise, devices may be damaged.
  - \* The load, such as a drawer kick-out solenoid, must be connected between pins 4 and 2 or pins 4 and 5 of the drawer kick connector.
  - \* When the drawer open/close signal is used, a switch must be provided between drawer kick connector pins 3 and 6.
  - \* The resistance of the load, such as a drawer kick-out solenoid, must be  $24\ \Omega$  or more or the input current must be 1 A or less.
  - \* Be sure to use the 24 V power output on drawer kick connector pin 4 for driving the equipment.
- Use a shield cable for the drawer connector cable.
- Two driver transistors cannot be energized simultaneously.
- Leave intervals longer than 4 times the drawer driving pulse when sending it continuously.
- Be sure to use the printer power supply (connector pin 4) for the drawer power source.
- Do not insert a telephone line into the drawer kick connector. Doing so may damage the telephone line or printer.

1. Connect the drawer cable to the drawer kick connector (labeled DK) on the connector panel.



Drawer kick connector

#### **Note:**

The connector panel varies depending on the models.

**Adaptable Connector**

Modular connector RJ12

**Pin assignments**

| Pin number | Signal name                   | Direction |
|------------|-------------------------------|-----------|
| 1          | Frame GND                     | -         |
| 2          | Drawer kick drive signal 1    | Output    |
| 3          | Drawer kick open/close signal | Input     |
| 4          | +24 V                         | -         |
| 5          | Drawer kick drive signal 2    | Output    |
| 6          | Signal GND                    | -         |

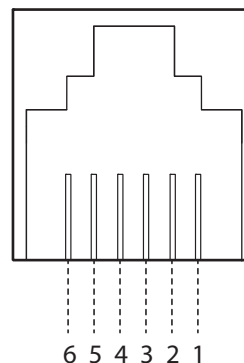

**3.3.1 Setting the internal buzzer (for models with an internal buzzer)**

Models with the buzzer function can beep the buzzer when the drawer is opened, by setting the properties of the driver or outputting a pulse signal by a command. The internal buzzer cannot change the buzzer volume and sound pattern but can change the buzzer frequency. When using the internal buzzer, you need to enable the internal buzzer with the memory switch. The buzzer setting is performed by setting the memory switches for the buzzer and specifying connector pin numbers to which a command outputs a pulse signal, as shown in the table below. For information about the memory switches, see ["Memory Switch Settings" on page 42](#).

| Memory switch              | Specified connector pin     | ON            | OFF                   | Initial setting |
|----------------------------|-----------------------------|---------------|-----------------------|-----------------|
| Buzzer frequency (Pulse 1) | Drawer kick connector pin 2 | Buzzer beeps. | Buzzer does not beep. | OFF             |
| Buzzer frequency (Pulse 2) | Drawer kick connector pin 5 | Buzzer beeps. | Buzzer does not beep. | ON              |

**⚠ CAUTION:**

Since the buzzer drive signal and the cash drawer drive signal are common in the printer, do not use the same connector pin numbers to output the signal for the buzzer and the cash drawer.

**📝 Note:**

For detailed information about ESC/POS commands, see the ESC/POS Command Reference. For details on how to obtain this manual, see ["Introduction of Control Methods" on page 83](#). For detailed information about the driver control, see the manual for each driver.



## Chapter 4

# Setting/Checking Modes

### 4.1 Setting/Checking Modes of TM-L90 4\*\* models, TM-L90 Peeler 39\* models

Besides the ordinary print mode, the printer has the following modes to set or check settings of the printer.

- ❑ Self-test Mode
- ❑ NV Graphics Information Print Mode (page 77)
- ❑ Memory Switch Setting Mode (page 78)
- ❑ Hexadecimal Dump Mode (page 79)

The self-test mode or hexadecimal dumping mode is selected depending on the operation performed when the power is turned on.

NV graphic information print mode and the memory switch setting mode are selected depending on the FEED button operation performed during a self-test.

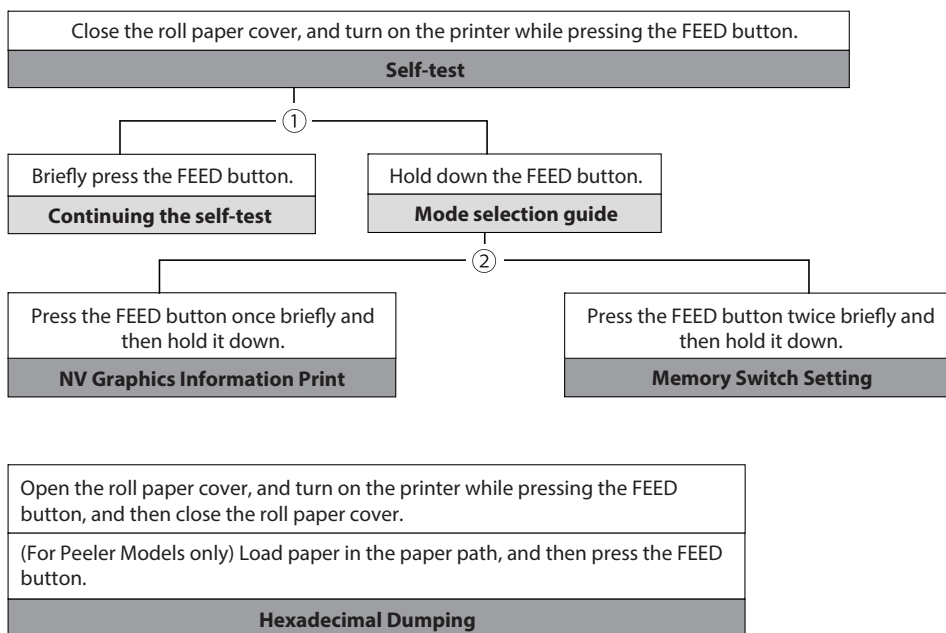

In 1 and 2, the following guidances are printed, the PAPER OUT LED flashes, and instructs the user's operations.

1. Continuing self-test guidance

```
Select Modes by pressing Feed Button.  
Continue SELF-TEST: Less than 1 second  
Mode Selection      : 1 second or more
```

2. Mode selection guidance

```
Mode Selection  
  
Modes  
0: Exit and Reboot Printer  
1: NV Graphics Information  
2: Customize Value Settings  
3 or more: None  
  
Select Modes by executing following  
procedure.  
step 1. Press the Feed button less  
        than 1 second as many times  
        as the selected mode number.  
step 2. Press Feed button for 1  
        second or more.
```

#### 4.1.1 Self-test Mode

You can check the following items using the self-test.

- Firmware version
- Interface type
- Receive buffer size
- BUSY condition
- Resident font
- Whether or not there are auto carriage returns
- Setting status of the interface reset signal
- Print density
- Power-on notification setting
- Paper width setting
- Paper type
- All types of sensor thresholds
- Print speed setting
- Maintenance counter information (head running length, number of times of autocutting)

- Memory switch settings

Follow the steps below.

1. Close the roll paper cover.
2. Turn on the power while pressing FEED button. Keep pressing the button until the ERROR LED comes on.

After printing the current status, a Continuing self-test guidance is printed, and the PAPER OUT LED flashes.

3. Briefly press the FEED button (less than one second) to continue the self-test. If the test does not continue, turn off the power.

When the self-test continues, rolling printing is performed with the loaded text. After "\*\*\* completed \*\*\*" is printed, the printer initializes and switches to standard mode.

#### **4.1.2 NV Graphics Information Print Mode**

You can confirm the following information with this mode:

- Capacity of the NV graphics
- Used capacity of the NV graphics
- Unused capacity of the NV graphics
- Number of NV graphics that are registered
- Key code, number of dots in X direction, number of dots in Y direction, number of colors to be defined.
- NV graphics data

Follow the steps below.

1. Close the roll paper cover.
2. Turn on the power while pressing FEED button. Keep pressing the button until the ERROR LED comes on.

After printing the current status, a Continuing self-test guidance is printed, and the PAPER OUT LED flashes.

3. Hold down the FEED button (for at least one second) to shift to Mode selection.

Mode selection guidance is printed, and the PAPER OUT LED flashes.

4. After briefly (less than one second) pressing the FEED button once, hold it down for at least one second, to print the NV graphics information.

After information printing, the Mode selection guidance is printed again.

5. To finish, turn off the power, or select "Exit and Reboot Printer".

### 4.1.3 Memory Switch Setting Mode

Use the following procedure to start this mode.

1. Close the roll paper cover.
2. Turn on the power while pressing FEED button. Keep pressing the button until the ERROR LED comes on.

After printing the current status, a Continuing self-test guidance is printed, and the PAPER OUT LED flashes.

3. Hold down the FEED button (for at least one second) to shift to Mode selection.

Mode selection guidance is printed, and the PAPER OUT LED flashes.

4. After briefly (less than one second) pressing the FEED button twice, hold it down for at least one second, and then select memory switch setting mode (Customize Value Settings).

A guidance for the Memory switch setting mode is printed, and the PAPER OUT LED flashes.

TM-L90

TM-L90 Peeler

| TM-L90                                                                                                                                                                                                                                                                                                                                                                                                                                                                                                                                                                                                                                                                                                                                                                                           | TM-L90 Peeler                                                                                                                                                                                                                                                                                                                                                                                                                                                                                                                                                                                                                                                                                          |
|--------------------------------------------------------------------------------------------------------------------------------------------------------------------------------------------------------------------------------------------------------------------------------------------------------------------------------------------------------------------------------------------------------------------------------------------------------------------------------------------------------------------------------------------------------------------------------------------------------------------------------------------------------------------------------------------------------------------------------------------------------------------------------------------------|--------------------------------------------------------------------------------------------------------------------------------------------------------------------------------------------------------------------------------------------------------------------------------------------------------------------------------------------------------------------------------------------------------------------------------------------------------------------------------------------------------------------------------------------------------------------------------------------------------------------------------------------------------------------------------------------------------|
| <p style="text-align: center;"><b>Customize Value Settings</b></p> <p>Modes</p> <ul style="list-style-type: none"><li>0: Exit</li><li>1: Print Current Settings</li><li>2: Print Density</li><li>3: Serial Interface Settings</li><li>4: Paper Width</li><li>5: Default Character</li><li>6: Embedded Font Replacement</li><li>7: Interface Selection</li><li>8: USB Interface Settings</li><li>9: Printing Speed</li><li>10: Auto Cut</li><li>11: Label Settings</li><li>12: Paper Feed Settings</li><li>13: Other Settings</li></ul> <p>Select Modes by executing following procedure.</p> <ul style="list-style-type: none"><li>step 1. Press the Feed button less than 1 second as many times as the selected mode number.</li><li>step 2. Press Feed button for 1 second or more.</li></ul> | <p style="text-align: center;"><b>Customize Value Settings</b></p> <p>Modes</p> <ul style="list-style-type: none"><li>0: Exit</li><li>1: Print Current Settings</li><li>2: Print Density</li><li>3: Serial Interface Settings</li><li>4: Paper Width</li><li>5: Default Character</li><li>8: USB Interface Settings</li><li>9: Printing Speed</li><li>11: Label Settings</li><li>12: Paper Feed Setting</li><li>13: Other Settings</li></ul> <p>Select Modes by executing following procedure.</p> <ul style="list-style-type: none"><li>step 1. Press the Feed button less than 1 second as many times as the selected mode number.</li><li>step 2. Press Feed button for 1 second or more.</li></ul> |

5. After briefly pressing the FEED button (less than one second) for the number of times shown in the print result, hold down the button for more than one second, and then select the setting items.

The setting selected as the setting item, the current settings and initial settings are printed. Depending on the setting item, you may need to continue making the setting item before the settings are printed.

See ["Setting items for Memory Switch Setting Mode" on page 119](#) for setting items and settings.

6. Select a setting by briefly pressing the FEED button (less than one second) for the number of times applicable to the setting, and then hold down the button for more than one second to confirm your selection.

After saving the settings, a guidance for the Memory switch setting mode is printed, and the PAPER OUT LED flashes.

7. To close Memory switch setting mode, turn off the printer, or select "Exit" to return to Mode selection guidance, and then select "Exit and Reboot Printer".



**Note:**

- ❑ To select 0 as the item number, hold down the FEED button until printing starts.
- ❑ If the button is pressed a number of times that is not displayed by the guidance, the operation is invalid and the same guidance is printed.

#### 4.1.4 Hexadecimal Dump Mode

TM printer can print the data transmitted from the host computer in hexadecimal numbers and in their corresponding characters. This is called hexadecimal dump mode, which allow you to make sure the transmission is correct by comparing the printed result with the programs.

Use the following procedure to output a hexadecimal dump.

1. For TM-L90, open the roll paper cover.  
For TM-L90 Peeler, open the peeler cover and the roll paper cover.
2. Turn on the power while pressing FEED button inside the printer. Keep pressing the button until the ERROR LED comes on.
3. For TM-L90, close the roll paper cover.  
For TM-L90 Peeler, close the roll paper cover, and then after loading paper in the paper path, press the paper feed switch.

Data received after this is printed in hexadecimal numbers and their corresponding characters.

4. When printing stops, turn off the power or press the FEED button three times or send a reset signal from the interface.



**Note:**

Do not use this mode when using OPOS. To do so will cause continuous polling, ending in undesirable results.

---

## 4.2 Setting/Checking Modes of TM-L90 other than 4\*\* models, TM-L90 Peeler other than 39\* models

Besides the ordinary print mode, the printer has the following modes to set or check settings of the printer.

- Self-test Mode
- Memory Switch Setting Mode (page 81)
- Hexadecimal Dump Mode (page 82)

The mode is selected depending on the operation performed when turning on the printer.

|                                                                                     |
|-------------------------------------------------------------------------------------|
| Close the roll paper cover, and turn on the printer while pressing the FEED button. |
| <b>Self-test</b>                                                                    |

|                                                                                                                                                         |
|---------------------------------------------------------------------------------------------------------------------------------------------------------|
| Open the roll paper cover, and turn on the printer while pressing the FEED button, and then press the FEED button twice and close the roll paper cover. |
| (For Peeler Models only) Load paper in the paper path, and then press the FEED button.                                                                  |
| <b>Memory Switch Setting</b>                                                                                                                            |

|                                                                                                                         |
|-------------------------------------------------------------------------------------------------------------------------|
| Open the roll paper cover, and turn on the printer while pressing the FEED button, and then close the roll paper cover. |
| (For Peeler Models only) Load paper in the paper path, and then press the FEED button.                                  |
| <b>Hexadecimal Dumping</b>                                                                                              |

### 4.2.1 Self-test Mode

You can check the following items using the self-test.

- Firmware version
- Interface type
- Receive buffer size
- BUSY condition
- Resident font
- Whether or not there are auto carriage returns
- Power-on notification setting
- Print density
- Setting status for power ON

- Paper width setting
- Paper type
- All types of sensor thresholds
- Print speed setting
- Dip switch settings
- Memory switch settings

Follow the steps below.

1. Close the roll paper cover.
2. Turn on the power while pressing FEED button. Keep pressing the button until the ERROR LED comes on.

After printing the current status, a Continuing self-test guidance is printed, and the PAPER OUT LED flashes.

3. Briefly press the FEED button (less than one second) to continue the self-test. If the test does not continue, turn off the power.

When the self-test continues, rolling printing is performed with the loaded text.

After "\*\*\* completed \*\*\*" is printed, the printer initializes and switches to standard mode.

#### **4.2.2 Memory Switch Setting Mode**

Use the following procedure to start this mode.

1. For TM-L90, open the roll paper cover.  
For TM-L90 Peeler, open the peeler cover and the roll paper cover.
2. Turn on the power while pressing FEED button inside the printer. Keep pressing the button until the ERROR LED comes on.
3. Press the FEED button twice.
4. For TM-L90, close the roll paper cover.  
For TM-L90 Peeler, close the roll paper cover, and then after loading paper in the paper path, press the paper feed switch.

The printer will print out a guidance and then enter the Memory Switch Setting Mode.

5. Follow the guidance to use the mode.

See the "[Setting items for Memory Switch Setting Mode](#)" on page 119 for setting items and settings.

### 4.2.3 Hexadecimal Dump Mode

TM printer can print the data transmitted from the host computer in hexadecimal numbers and in their corresponding characters. This is called hexadecimal dump mode, which allow you to make sure the transmission is correct by comparing the printed result with the programs.

Use the following procedure to output a hexadecimal dump.

1. For TM-L90, open the roll paper cover.  
For TM-L90 Peeler, open the peeler cover and the roll paper cover.
2. Turn on the power while pressing FEED button inside the printer. Keep pressing the button until the ERROR LED comes on.
3. For TM-L90, close the roll paper cover.  
For TM-L90 Peeler, close the roll paper cover, and then after loading paper in the paper path, press the paper feed switch.

Data received after this is printed in hexadecimal numbers and their corresponding characters.

4. When printing stops, turn off the power or press the FEED button three times or send a reset signal from the interface.



**Note:**

*Do not use this mode when using OPOS. To do so will cause continuous polling, ending in undesirable results.*

## Chapter 5

# Application Development Information

---

This chapter introduces how to control this printer and the information useful for development of applications using this printer.

### 5.1 Introduction of Control Methods

The TM printer can print and be controlled by any of the following three methods.

1. Windows printer driver (EPSON Advanced Printer Driver)
2. EPSON OPOS ADK
3. ESC/POS commands

Depending on the driver and interface used, the IP setup tool for Ethernet specifications, USB device driver, printing logo registration utility (TMFlash logo utility), etc. are available. Get the latest information from the following URL.

For customers in North America, go to the following web site:

<https://www.epson.com/support/>

For customers in other countries and regions, go to the following web site:

<https://epson.sn>

For detailed information about ESC/POS commands, see the ESC/POS Command Reference for TM Printers that can be accessed from the following URL:

[https://support.epson.net/publist/reference\\_en/](https://support.epson.net/publist/reference_en/)

#### 5.1.1 Windows Driver (EPSON Advanced Printer Driver)

EPSON Advanced Printer Driver is a Windows driver for TM printers.

##### 5.1.1.1 EPSON Advanced Printer Driver Overview

EPSON Advanced Printer Driver has the following features.

- ❑ Supplies the Windows printer driver for TM printers to enable printing from a general Windows application.
- ❑ Can execute POS printer-specific functions such as paper cutting and drawer opening.
- ❑ Can print the printer resident font by selecting the font type.
- ❑ Can get the printer status using programming languages such as VB via Status API. This uses the bidirectional communication of the TM printer in the Windows standard printer driver operation environment.



**Note:**

Status API is the printer control API supplied originally by Epson. This can be used to get the printer status and send ESC/POS commands.

### 5.1.1.2 EPSON Advanced Printer Driver Contents

The installer automatically judges the target PC environment and automatically installs the DLL and software components necessary for operation. You can select the drivers, sample programs, and manuals to be installed.

#### Drivers

You can select the driver according to the purpose of use. (Drivers can be installed simultaneously.) They include smoothing, continuous printing, cutting method option and other functions.

- With TM-L90
  - Receipt: For receipt printing
  - Reduce 35: A4 vertical size can be reduced 35% to enable printing on receipts of 80 mm width.
  - Label: For label printing
- With the TM-L90 Peeler Model
  - Receipt: For continuous printing
  - Label: For printing label paper

#### Sample programs

Sample programs in Visual Basic and Visual C++ to use Status API can be installed.

#### Manuals

The following manuals can be installed.

- With TM-L90
  - Driver: User's Manual
  - Status API: Reference Manual
- With the TM-L90 Peeler Model
  - User's Guide (Developer's Guide)

### 5.1.1.3 EPSON Advanced Printer Driver Support Environment

#### Supported interfaces

- Serial, Parallel, USB, Ethernet, Wireless LAN

#### Supported OSs (with confirmation of system operation)

For details on the supported operating systems, see the release note of the driver for the latest information.

#### Supported development languages

For details on the supported development languages, see the release note of the driver for the latest information.

#### Supported devices

(Refer to the release note of the driver for details of available equipment.)

- Epson receipt printer
- Epson customer display
- Epson cash drawer



#### **Note:**

The USB interface models require USB device driver. The Ethernet or Wireless LAN interface models require IP setting utility. For the details, refer to the packaged APD manual.

When the TM-L90 is connected via a serial interface, it is recommended to use the printer resident font since use of the TrueType font will decrease printing speed due to the transfer speed of the serial interface. For how to use the resident font, refer to the PDF User's Manual of APD.

The other interfaces (parallel, USB, Ethernet) do not pose problems in terms of the transfer speed but may have some influence on customer applications. In that case, use the printer resident font. When OPOS is used, this problem does not arise because only the printer resident font is available.

### 5.1.1.4 Driver Information and Download Destination

See ["Introduction of Control Methods"](#) on page 83.

## 5.1.2 EPSON OPOS ADK

EPSON OPOS ADK supports the development environment required for OPOS application development by OPOS Control proposed by the OLE for Retail POS (hereafter OPOS) Technology Association to supply the OPOS-compliant printer driver (OCX).

Use this control method to develop an OPOS-compliant application. EPSON OPOS ADK has the following features.

- EPSON OPOS ADK totally supports the development environment required for OPOS application development for customers, including not only OPOS Control (CO + SO) proposed by the OPOS Association, but also the contents necessary for development, ranging from the installers and setup utilities to sample programs and manuals, the function to get a log for debugging, and silent installation that realizes ease of installation to a target PC.

- ❑ EPSON OPOS ADK enables you to reduce the man-hours for the application development since it includes the following functions that application developers have to consider. The functions are: Support with the Epson-original Direct IO with a parameter, the power-on notification, and off-line buffer clear processing.



**Note:**

*For detailed information on the API functions, see the UnifiedPOS specification available at the following web site:*

*<https://www.omg.org/spec/UPOS>*

### 5.1.2.1 EPSON OPOS ADK (OPOS Control) Overview

OPOS Control included with EPSON OPOS ADK has the following features.

- ❑ Supplies CO for each device class and SO for Epson devices.
  - ❑ Direct IO with parameters available.
    - Gets the maintenance counter value of the printer.
    - NVRAM-registered electronic logo (bit image) printing, etc. (For the electronic logo, refer to ["Electronic Logo Registration Utility for NVRAM" on page 89.](#))
  - ❑ Power-on notification function (at power-on, this function automatically restores the printer to the state prior to the power-off)
  - ❑ Offline buffer clear processing (clears the print buffer contents in the offline mode)
  - ❑ Debugging function (trace function)
    - Gets a log between the application and CO (target: Used API and its return value)
    - Device status getting log (gets the offline and error factors that actually occurred in the devices)
- and so on.

### 5.1.2.2 EPSON OPOS ADK Contents

The installer of EPSON OPOS ADK Ver. 2.10 or later has the silent installation function, which can install the OPOS environment without a user interface, to facilitate installation. With the installer, the following OPOS-compliant OPOS Control for Epson devices, manuals, various utilities and sample programs can be installed.

- ❑ OPOS Control for Epson devices

Header files for CO, SO, C++, header file for VB, TLB file of CO, device information file, etc. can be installed.

- ❑ Manuals
  - User's Guide (Environment construction manual: Installation/uninstallation, various utility using methods)
  - Application Development Guide (Manual for OPOS-compliant application developer: Common manual, Each device manual)

❑ Utilities packed with various drivers

- SetUpPOS Utility

Equipment and connection ports can be selected, and various settings can be made. (Paper size, print waiting time setting, etc.)

- TM Flash logo utility

A bitmap file can be registered to the printer or customer display, for example.

- USB device driver

Driver necessary to connect the USB interface printer.

- Sample programs

Sample programs in VB, VC++ can be installed.

### **5.1.2.3 EPSON OPOS ADK Support Environment**

#### *Supported interfaces*

- Serial, Parallel, USB, Ethernet, Wireless LAN

#### *Supported OSs (with confirmation of system operation)*

For details on the supported operating systems, see the release note of the driver for the latest information.

#### *Supported development languages*

For details on the supported development languages, see the release note of the driver for the latest information.

### **5.1.2.4 Driver Information and Download Destination**

See ["Introduction of Control Methods" on page 83](#).

## **5.1.3 ESC/POS Commands**

Printing/control via ESC/POS commands is a method proposed by Epson to directly control the TM printer using ESC/POS commands. The printer can be controlled directly by sending ESC/POS commands from an application to the printer. For detailed information on the ESC/POS commands, see the ESC/POS Command Reference. For details on how to obtain this manual, see ["Introduction of Control Methods" on page 83](#).



**Note:**

The printer of Ethernet specifications requires the IP setup utility separately. For details on how to obtain the utility, see ["Various Utilities" on page 89](#).

### 5.1.4 Various Utilities

We provide the utilities as described below. Get the utilities from the following URL.

For customers in North America, go to the following web site:

<https://www.epson.com/support/>

For customers in other countries and regions, go to the following web site:

<https://epson.sn>

#### 5.1.4.1 Address Setup Utility for Ethernet Interface (for UB-E\*\*)

The utility, which sets an IP address to a 10BASE-T/100BASE-TX Ethernet interface for TM printer, and its detailed manual for developers are available. The customer who purchases the Ethernet interface TM printer needs this utility.

#### 5.1.4.2 Electronic Logo Registration Utility for NVRAM

This utility is designed to register a logo to the NVRAM (non-volatile memory) built in the printer. Using this utility saves shop logos to the NVRAM to increase logo printing speed.

#### 5.1.4.3 Memory Switch Setting Utility

This utility is designed to perform the memory switch-related functions of the TM printer easily.

- You can execute a communication test and self-test.
- You can set the switches, etc. (such as the memory switches and customized values).
- You can set the paper layout for the TM-L90.

#### 5.1.4.4 USB Interface ID Code Rewrite Utility

This utility is designed to edit the identification code of a USB interface according to the purpose of the user of USB interface TM printer. When you do not want to change the USB port setting of the driver after replacement of the TM printer, you do not need to change the port number by setting the same IP.

## 5.2 Sensors

### 5.2.1 Paper Sensors

The printer has two paper sensors.

#### 5.2.1.1 Roll paper near-end sensor

The roll paper near-end sensor is to detect the condition when the remaining amount of the paper is getting low and it is located on the roll paper supply unit. It detects the near-end of the roll paper by detecting the roll paper diameter. You can adjust the sensor position. See [page 25](#) for details for adjustment.

The normal printing task will be performed even in the near-end status.



**Note:**

*The detecting the near-end status of the sensor does not necessarily indicate the complete end of the roll paper. Use the sensor as an indication of replacing a roll paper.*

### 5.2.1.2 Roll Paper End Sensor

The roll paper end sensor is located in the paper path. It detects the presence of paper through the roll paper in the paper path.

When there is no paper in the path (paper end status), the ERROR LED and the PAPER OUT LED indicator will light and it will be in the error status.

If the sensor detects the roll paper end, the printer will stop printing even in the process of printing. It is recommended that you mainly use the roll paper near-end sensor and use the roll paper end sensor secondarily.

## 5.2.2 Printer Cover Sensor

### 5.2.2.1 Roll Paper Cover Open Sensor

The cover-open sensor monitors the roll paper cover. When the sensor detects an open cover while printing, the printer stops printing immediately and automatically goes offline. Depending on the Msw 8-8 setting, an open cover error is handled as either a recoverable error or unrecoverable error as described below.

- |                                                |                                                                                                                                                                                                                                           |
|------------------------------------------------|-------------------------------------------------------------------------------------------------------------------------------------------------------------------------------------------------------------------------------------------|
| <input type="checkbox"/> Msw 8-8 off:          | Automatically recoverable error. The ERROR LED flashes. When the printer cover is closed, the ERROR LED goes off, and the printer goes online and starts printing at the beginning of the line it was printing when the cover was opened. |
| <input type="checkbox"/> Msw 8-8 on: (Default) | Recoverable error. The ERROR LED flashes. Since the ERROR LED still flashes after the cover is closed, send the error recovery command to recover from the error.                                                                         |

When the printer recovers, it feeds paper to take up the slack, and starts printing from the beginning of the line where the error occurred. In this case, double printing and printing position shift may occur. It is recommended to set the memory switch Msw 8-8 to ON, clear the printer buffers by a command from the driver, and resend the print data.

Whether the cover is open or not does not affect the status reported by the roll paper end sensor.



**Note:**

*When OPOS or Advanced Printer Driver is used, do not change the default setting of the memory switch.*

### 5.2.2.2 Offline

This printer is not equipped with an online/offline switch. The printer goes offline under the following conditions automatically.

- When the power is turned on (including reset using the interface) and while the printer is ready to receive data.
- During the self test.
- When the roll paper cover is open.
- During paper feeding using the FEED button.

- When the printer stops printing due to a paper-end (in cases when an empty paper supply is detected by roll paper end detector or when it has been set to stop printing by the driver when the roll paper near-end sensor detects a paper end.)
- When an error has occurred.
- During macro executing standby status.
- Waiting for FEED status when inserting the roll paper (to complete the task of inserting the roll paper by pressing the FEED button)



**Note:**  
The off-line status also happens infrequently when the pulse of the drawer kick is sent.

### 5.2.2.3 Busy state

#### Selecting conditions that invoke a BUSY State

The conditions that invoke a BUSY condition are selected with memory switch setting mode or memory switch Msw1-3 as follows.

- When the receive buffer is full
- When the receive buffer is full or the printer is off-line



**Note:**  
In either case indicated above, it will be a BUSY status when turning on the power (including resetting with the interface), while the printer is in the state of receiving data and when executing a self-testing.

You do not need to change this item during the use of OPOS or Advanced Printer Driver.

#### Printer BUSY conditions and the Msw1-3 status

| Printer status                        |                                                                                                                                            | Memory switch Msw 1-3 state |      |
|---------------------------------------|--------------------------------------------------------------------------------------------------------------------------------------------|-----------------------------|------|
|                                       |                                                                                                                                            | ON                          | OFF  |
| Offline                               | During the period from when the power is turned on (including resetting using the interface) to when the printer is ready to receive data. | BUSY                        | BUSY |
|                                       | During the self test.                                                                                                                      | BUSY                        | BUSY |
|                                       | When the cover is open.                                                                                                                    | -                           | BUSY |
|                                       | During paper feeding using the paper feed button.                                                                                          | -                           | BUSY |
|                                       | When the printer stops printing due to a paper-end. (only when the roll paper is not present)                                              | -                           | BUSY |
|                                       | When an error has occurred.                                                                                                                | -                           | BUSY |
| When the receive buffer becomes full. |                                                                                                                                            | BUSY                        | BUSY |

### 5.2.2.4 Receive buffer

The capacity of the receive buffer is set using memory switch setting mode or memory switch Msw1-2. The definition of a receive buffer full is described in the following table. The printer ignores the data received when the remaining space in the receive buffer is 0 bytes.

| Memory switch Msw1-2 | Receive buffer capacity | Buffer full definition                                                                                           |
|----------------------|-------------------------|------------------------------------------------------------------------------------------------------------------|
| ON                   | 45 bytes                | From when the remaining space in the receive buffer drops to 16 bytes, to when the space increase to 26 bytes.   |
| OFF                  | 4 KB                    | From when the remaining space in the receive buffer drops to 128 bytes, to when the space increase to 256 bytes. |



**Note:**

When using OPOS or Advanced Printer Driver, you don't need to change the receive buffer.

### 5.2.3 Label Peeling Sensor (Peeler Specification Only)

This detects whether or not there is a peeled label. If a label is removed, the next label is moved to the printing start position.



**Note:**

If the printer is used in a location with direct sunlight, even when a label is removed, it may be determined as being present due to misdetection, and the printer continues waiting for label removal status. In this case, press the FEED button once to return the paper to the next label printing start position.

## 5.3 Barcode Printing

The TM-L90 / TM-L90 Peeler Model can print the types of barcode shown below.

- UPC-A, UPC-E
- JAN 8 (EAN 8), JAN 13 (EAN 13)
- CODE 39
- ITF (Interleaved 2 of 5)
- CODABAR (NW-7)
- CODE 93
- CODE 128
- GS1-128\*
- GS1 DataBar Omnidirectional\*
- GS1 DataBar Truncated\*
- GS1 DataBar Stacked\*
- GS1 DataBar Stacked Omnidirectional\*
- GS1 DataBar Limited\*
- GS1 DataBar Expanded\*
- GS1 DataBar Expanded Stacked\*
- PDF417
- MaxiCode

QRCode  
Composite Symbology\*  
DataMatrix\*

\*: Available only for TM-L90 4\*\* models or TM-L90 Peeler 39\* models

Refer to each document of OPOS, Printer Driver or ESC/POS commands for the setting/printing procedures of each barcode.

---

## **5.4 CODE 128 Barcode**

The CODE 128 barcode allows a single barcode character to represent one character of a full-ASCII 128-character set or two-digit number from among the combinations of 103 different barcode characters and three different code sets.

- Code set A: Can represent ASCII characters 00H to 5FH.
- Code set B: Can represent ASCII characters 20H to 7FH.
- Code set C: One character can represent a two-digit number (100 numbers from 00 to 99).

In addition to the above characters, CODE 128 also provides the following special characters.

- Shift character (SHIFT)  
The code set A handles the character right after SHIFT as a character of the code set B. The code set B handles the character right after SHIFT as a character of the code set A. SHIFT cannot be used in the code set C.
- Code set selection character (CODE A, CODE B, CODE C)  
Changes the subsequent code set to A, B or C.
- Function character (FNC1, FNC 2, FNC3, FNC4)  
The purpose of the function character changes depending on the application. The code set C accepts only FNC1.

Printable characters for code set A

| characters | Transmission data |              | characters | Transmission data |              | characters | Transmission data |              |
|------------|-------------------|--------------|------------|-------------------|--------------|------------|-------------------|--------------|
|            | Hexadecimal code  | Decimal code |            | Hexadecimal code  | Decimal code |            | Hexadecimal code  | Decimal code |
| NUL        | 00                | 0            | (          | 28                | 40           | P          | 50                | 80           |
| SOH        | 01                | 1            | )          | 29                | 41           | Q          | 51                | 81           |
| STX        | 02                | 2            | *          | 2A                | 42           | R          | 52                | 82           |
| ETX        | 03                | 3            | +          | 2B                | 43           | S          | 53                | 83           |
| EOT        | 04                | 4            | ,          | 2C                | 44           | T          | 54                | 84           |
| ENQ        | 05                | 5            | -          | 2D                | 45           | U          | 55                | 85           |
| ACK        | 06                | 6            | .          | 2E                | 46           | V          | 56                | 86           |
| BEL        | 07                | 7            | /          | 2F                | 47           | W          | 57                | 87           |
| BS         | 08                | 8            | 0          | 30                | 48           | X          | 58                | 88           |
| HT         | 09                | 9            | 1          | 31                | 49           | Y          | 59                | 89           |
| LF         | 0A                | 10           | 2          | 32                | 50           | Z          | 5A                | 90           |
| VT         | 0B                | 11           | 3          | 33                | 51           | [          | 5B                | 91           |
| FF         | 0C                | 12           | 4          | 34                | 52           | \          | 5C                | 92           |
| CR         | 0D                | 13           | 5          | 35                | 53           | ]          | 5D                | 93           |
| SO         | 0E                | 14           | 6          | 36                | 54           | ^          | 5E                | 94           |
| SI         | 0F                | 15           | 7          | 37                | 55           | _          | 5F                | 95           |
| DLE        | 10                | 16           | 8          | 38                | 56           | FNC1       | 7B,31             | 123,49       |
| DC1        | 11                | 17           | 9          | 39                | 57           | FNC2       | 7B,32             | 123,50       |
| DC2        | 12                | 18           | :          | 3A                | 58           | FNC3       | 7B,33             | 123,51       |
| DC3        | 13                | 19           | ;          | 3B                | 59           | FNC4       | 7B,34             | 123,52       |
| DC4        | 14                | 20           | <          | 3C                | 60           | SHIFT      | 7B,53             | 123,83       |
| NAK        | 15                | 21           | =          | 3D                | 61           | CODEB      | 7B,42             | 123,66       |
| SYN        | 16                | 22           | >          | 3E                | 62           | CODEC      | 7B,43             | 123,67       |
| ETB        | 17                | 23           | ?          | 3F                | 63           |            |                   |              |
| CAN        | 18                | 24           | @          | 40                | 64           |            |                   |              |
| EM         | 19                | 25           | A          | 41                | 65           |            |                   |              |
| SUB        | 1A                | 26           | B          | 42                | 66           |            |                   |              |
| ESC        | 1B                | 27           | C          | 43                | 67           |            |                   |              |
| FS         | 1C                | 28           | D          | 44                | 68           |            |                   |              |
| GS         | 1D                | 29           | E          | 45                | 69           |            |                   |              |
| RS         | 1E                | 30           | F          | 46                | 70           |            |                   |              |
| US         | 1F                | 31           | G          | 47                | 71           |            |                   |              |
| SP         | 20                | 32           | H          | 48                | 72           |            |                   |              |
| !          | 21                | 33           | I          | 49                | 73           |            |                   |              |
| "          | 22                | 34           | J          | 4A                | 74           |            |                   |              |
| #          | 23                | 35           | K          | 4B                | 75           |            |                   |              |
| \$         | 24                | 36           | L          | 4C                | 76           |            |                   |              |
| %          | 25                | 37           | M          | 4D                | 77           |            |                   |              |
| &          | 26                | 38           | N          | 4E                | 78           |            |                   |              |
| '          | 27                | 39           | O          | 4F                | 79           |            |                   |              |

Printable characters for code set B

| characters | Transmission data |              | characters | Transmission data |              | characters | Transmission data |              |
|------------|-------------------|--------------|------------|-------------------|--------------|------------|-------------------|--------------|
|            | Hexadecimal code  | Decimal code |            | Hexadecimal code  | Decimal code |            | Hexadecimal code  | Decimal code |
| SP         | 20                | 32           | H          | 48                | 72           | p          | 70                | 112          |
| !          | 21                | 33           | I          | 49                | 73           | q          | 71                | 113          |
| "          | 22                | 34           | J          | 4A                | 74           | r          | 72                | 114          |
| #          | 23                | 35           | K          | 4B                | 75           | s          | 73                | 115          |
| \$         | 24                | 36           | L          | 4C                | 76           | t          | 74                | 116          |
| %          | 25                | 37           | M          | 4D                | 77           | u          | 75                | 117          |
| &          | 26                | 38           | N          | 4E                | 78           | v          | 76                | 118          |
| '          | 27                | 39           | O          | 4F                | 79           | w          | 77                | 119          |
| (          | 28                | 40           | P          | 50                | 80           | x          | 78                | 120          |
| )          | 29                | 41           | Q          | 51                | 81           | y          | 79                | 121          |
| *          | 2A                | 42           | R          | 52                | 82           | z          | 7A                | 122          |
| +          | 2B                | 43           | S          | 53                | 83           | {          | 7B,7B             | 123,123      |
| ,          | 2C                | 44           | T          | 54                | 84           |            | 7C                | 124          |
| -          | 2D                | 45           | U          | 55                | 85           | }          | 7D                | 125          |
| .          | 2E                | 46           | V          | 56                | 86           | —          | 7E                | 126          |
| /          | 2F                | 47           | W          | 57                | 87           | DEL        | 7F                | 127          |
| 0          | 30                | 48           | X          | 58                | 88           | FNC1       | 7B,31             | 123,49       |
| 1          | 31                | 49           | Y          | 59                | 89           | FNC2       | 7B,32             | 123,50       |
| 2          | 32                | 50           | Z          | 5A                | 90           | FNC3       | 7B,33             | 123,51       |
| 3          | 33                | 51           | [          | 5B                | 91           | FNC4       | 7B,34             | 123,52       |
| 4          | 34                | 52           | \          | 5C                | 92           | SHIFT      | 7B,53             | 123,83       |
| 5          | 35                | 53           | ]          | 5D                | 93           | CODEA      | 7B,41             | 123,66       |
| 6          | 36                | 54           | ^          | 5E                | 94           | CODEC      | 7B,43             | 123,67       |
| 7          | 37                | 55           | _          | 5F                | 95           |            |                   |              |
| 8          | 38                | 56           | `          | 60                | 96           |            |                   |              |
| 9          | 39                | 57           | a          | 61                | 97           |            |                   |              |
| :          | 3A                | 58           | b          | 62                | 98           |            |                   |              |
| ;          | 3B                | 59           | c          | 63                | 99           |            |                   |              |
| <          | 3C                | 60           | d          | 64                | 100          |            |                   |              |
| =          | 3D                | 61           | e          | 65                | 101          |            |                   |              |
| >          | 3E                | 62           | f          | 66                | 102          |            |                   |              |
| ?          | 3F                | 63           | g          | 67                | 103          |            |                   |              |
| @          | 40                | 64           | h          | 68                | 104          |            |                   |              |
| A          | 41                | 65           | i          | 69                | 105          |            |                   |              |
| B          | 42                | 66           | j          | 6A                | 106          |            |                   |              |
| C          | 43                | 67           | k          | 6B                | 107          |            |                   |              |
| D          | 44                | 68           | l          | 6C                | 108          |            |                   |              |
| E          | 45                | 69           | m          | 6D                | 109          |            |                   |              |
| F          | 46                | 70           | n          | 6E                | 110          |            |                   |              |
| G          | 47                | 71           | o          | 6F                | 111          |            |                   |              |

Printable characters for code set C

| characters | Transmission data |              | characters | Transmission data |              | characters | Transmission data |              |
|------------|-------------------|--------------|------------|-------------------|--------------|------------|-------------------|--------------|
|            | Hexadecimal code  | Decimal code |            | Hexadecimal code  | Decimal code |            | Hexadecimal code  | Decimal code |
| 00         | 00                | 0            | 40         | 28                | 40           | 80         | 50                | 80           |
| 01         | 01                | 1            | 41         | 29                | 41           | 81         | 51                | 81           |
| 02         | 02                | 2            | 42         | 2A                | 42           | 82         | 52                | 82           |
| 03         | 03                | 3            | 43         | 2B                | 43           | 83         | 53                | 83           |
| 04         | 04                | 4            | 44         | 2C                | 44           | 84         | 54                | 84           |
| 05         | 05                | 5            | 45         | 2D                | 45           | 85         | 55                | 85           |
| 06         | 06                | 6            | 46         | 2E                | 46           | 86         | 56                | 86           |
| 07         | 07                | 7            | 47         | 2F                | 47           | 87         | 57                | 87           |
| 08         | 08                | 8            | 48         | 30                | 48           | 88         | 58                | 88           |
| 09         | 09                | 9            | 49         | 31                | 49           | 89         | 59                | 89           |
| 10         | 0A                | 10           | 50         | 32                | 50           | 90         | 5A                | 90           |
| 11         | 0B                | 11           | 51         | 33                | 51           | 91         | 5B                | 91           |
| 12         | 0C                | 12           | 52         | 34                | 52           | 92         | 5C                | 92           |
| 13         | 0D                | 13           | 53         | 35                | 53           | 93         | 5D                | 93           |
| 14         | 0E                | 14           | 54         | 36                | 54           | 94         | 5E                | 94           |
| 15         | 0F                | 15           | 55         | 37                | 55           | 95         | 5F                | 95           |
| 16         | 10                | 16           | 56         | 38                | 56           | 96         | 60                | 96           |
| 17         | 11                | 17           | 57         | 39                | 57           | 97         | 61                | 97           |
| 18         | 12                | 18           | 58         | 3A                | 58           | 98         | 62                | 98           |
| 19         | 13                | 19           | 59         | 3B                | 59           | 99         | 63                | 99           |
| 20         | 14                | 20           | 60         | 3C                | 60           | FNC1       | 7B,31             | 123,49       |
| 21         | 15                | 21           | 61         | 3D                | 61           | CODEA      | 7B,41             | 123,65       |
| 22         | 16                | 22           | 62         | 3E                | 62           | CODEB      | 7B,42             | 123,66       |
| 23         | 17                | 23           | 63         | 3F                | 63           |            |                   |              |
| 24         | 18                | 24           | 64         | 40                | 64           |            |                   |              |
| 25         | 19                | 25           | 65         | 41                | 65           |            |                   |              |
| 26         | 1A                | 26           | 66         | 42                | 66           |            |                   |              |
| 27         | 1B                | 27           | 67         | 43                | 67           |            |                   |              |
| 28         | 1C                | 28           | 68         | 44                | 68           |            |                   |              |
| 29         | 1D                | 29           | 69         | 45                | 69           |            |                   |              |
| 30         | 1E                | 30           | 70         | 46                | 70           |            |                   |              |
| 31         | 1F                | 31           | 71         | 47                | 71           |            |                   |              |
| 32         | 20                | 32           | 72         | 48                | 72           |            |                   |              |
| 33         | 21                | 33           | 73         | 49                | 73           |            |                   |              |
| 34         | 22                | 34           | 74         | 4A                | 74           |            |                   |              |
| 35         | 23                | 35           | 75         | 4B                | 75           |            |                   |              |
| 36         | 24                | 36           | 76         | 4C                | 76           |            |                   |              |
| 37         | 25                | 37           | 77         | 4D                | 77           |            |                   |              |
| 38         | 26                | 38           | 78         | 4E                | 78           |            |                   |              |
| 39         | 27                | 39           | 79         | 4F                | 79           |            |                   |              |

## **5.5 Precautions for Two-Dimensional Code Printing**

This printer can print two-dimensional codes. The following two-dimensional codes can be printed.

- PDF417
- QRCode
- MaxiCode
- Composite Symbology\*
- DataMatrix\*

\*: Available only for TM-L90 4\*\* models

Note the following for two-dimensional code printing.

- The two-dimensional code recognition ratio changes depending on the module width, print density, environmental temperature, roll paper (thermal paper) type, reader performance, etc. Therefore, pre-check the recognition ratio and set the operating conditions to satisfy the restrictions of the reader.
- For PDF417 (two-dimensional code) printing, it is recommended to set the height of one symbol to three to five times greater than the module width. It is also recommended to set the overall height of the code to more than 5 mm (approximately).

## **5.6 NV Memory**

NV memory is embedded in the printer. Please use NV memory with attention to the following:

- The following restrictions apply when performing nonvolatile memory operations (including data store and delete).
  - The paper feed switch must not be used to feed paper.
  - The real time command must not be executed.
  - The ASB status will not be sent, even when the ASB function in ESC/POS command is set to enable.
- The printer will sometimes enter the Busy state when data is being written to nonvolatile memory. It is important not to send data from the host computer while the printer is in the Busy state as it will be incapable of processing any received data.
- Frequent use of the functions for defining data to and deleting data from nonvolatile memory can damage the memory. As a rule, in using the various commands to write to NV memory, avoid writing more than an average of 10 times per day.

## **5.7 FAQ List**

The questions shown in the list below begin with "Q" and their replies with "A"

1. Look through sentences beginning with "Q" to find information relating to your question or problem.
2. Then follow the instructions described in the "A" sentence below it.

*Q: Print data dropout occurs.*

*A: Check the handshake process.*

Data dropout can occur when the handshake between the host computer and the printer is not performed correctly. This can result in errors related to print buffer capacity.

### *Confirmation procedure*

Use the following steps to check the handshake process.

1. Select a comparatively large volume of data for printing and send it to the printer.
2. Enable the on-line state by opening the printer cover while the printer is printing.
3. Check the data send operation.
  - If data send terminates: Handshake process is normal
  - If data send continues: Handshake process is abnormal
4. In cases where the handshake process is found to be abnormal, follow the steps listed in Corrective Procedure shown below and re-enter host unit and printer settings so that they match.

### *Corrective procedure*

1. Confirm the serial communication cable.  
Confirm the specification of cable connection. ["Connecting the Cable" on page 63.](#)
2. Confirm serial communication condition.  
Confirm serial communication condition of printer and host.

Serial communication conditions

- Baud rate
- Parity
- Flow control
- Data length

Confirmation and setting of printer are as follows.

1. Confirm serial communication condition of the printer by self-test (See [page 42](#)).

2. Confirm DIP SW 1-2.

Printer serial communication condition can be set by DIP SW and memory switch. When the printer is powered on, DIP SW 1-2 selects DIP SW setting or memory switch setting as initial communication condition. Selected setting is printed by self-test.

DIP SW1-2 OFF: Used communication condition set by memory switch.

ON: Used communication condition set by DIP SW.

3. Set communication condition

When DIP SW1-2 is ON

Follow the procedure ([page 40](#)) and set.

When DIP SW1-2 is OFF

Follow the serial communication conditions ([page 42](#)). There are two ways to set it. Refer to "[Memory Switch Settings](#)" on [page 42](#) or "[Memory Switch Setting Utility](#)" on [page 89](#).



**Note:**

TM-L90 4\*\* models or TM-L90 Peeler 39\* models do not have the DIP switches; however, various functions can be set with memory switches. For detailed information about the memory switches, see "[Memory Switch Settings](#)" on [page 42](#).

Q: Drawer Kick does not operate properly.

A: Drawer specifications differ depending on the manufacturer and the part number.

Refer to "[Connecting the Cash Drawer](#)" on [page 72](#) and check that the cash drawer meets the required specifications.

Q: Unable to print a part of Page 0 (for example **ă**, **ú**, **ě**) in Visual Basic.

A: When programming with Visual Basic, limitations prevent data from 81h through 9Fh and E0h through FEh from being sent as characters. However, you can use the following procedure to send this data.

**Dim Send\_data(0) As Byte**

**Send\_data(0) = &h81 '1 byte of sending data**

**MSComm1.Output = Send\_data**

Q: Does USB 2.0-compatible equipment accept the USB interface printer?

A: Yes, but note that the speed of communication between the USB2.0 equipment and the printer is "USB full speed mode."



**Note:**

USB2.0 defines three speeds: High speed (480 Mbps), Full speed (12 Mbps) and Low speed (1.5 Mbps). This printer supports only Full speed (12 Mbps) and Low speed (1.5 Mbps).



## Chapter 6

---

# ESC/POS Command-Related Information

This chapter introduces the printer operation settings that can be made with ESC/POS commands and their precautions.

---

### 6.1 TM Printer Operation Performed When Power Switch is Disabled

**Note:**

*This function is available only for TM-L90 other than 4\*\* models or TM-L90 Peeler other than 39\* models.*

When the power switch is disabled with the DIP switches (refer to "[DIP Switch Settings](#)" on page 40), the power switch is always on. In other words, the power of the TM printer is on when power is supplied, and is off when power is not supplied by the system.

When the power switch is disabled, the TM printer is reset by pressing the power switch more than 3 seconds. This is true for both recoverable and unrecoverable errors.

When the power switch is disabled, a software power off preparation process must be executed for the TM printer from the application before the power supply is turned off. When the power switch is disabled, main power does not turn off and the POWER LED flashes if a software power off process is executed.

\* Power off process: The TM printer stores the latest TM printer condition before power down. Refer to the ESC/POS Command Reference for details.

### 6.1.1 Power Switch-Related User Operation List

|                                           | Power switch enabled                                                                                  | Power switch disabled                                                                                                                                 |
|-------------------------------------------|-------------------------------------------------------------------------------------------------------|-------------------------------------------------------------------------------------------------------------------------------------------------------|
| When you want to power on the TM printer  | Press the power switch more than 1 second.                                                            | Power on the system power supply.<br>Turn on the power breaker or outlet.                                                                             |
| When you want to power off the TM printer | Press the power switch more than 3 seconds.                                                           | Execute the software power off process using a software command and wait until the POWER LED starts flashing. Then power off the system power supply. |
| When there is a power outage              | The TM printer is powered off.                                                                        | The TM printer is powered off.                                                                                                                        |
| When the power outage is over             | The TM printer remains powered off. Press the power switch more than 1 second to turn the printer on. | The TM printer is powered on.                                                                                                                         |
| There is an unrecoverable error           | Press the power switch more than 3 seconds to turn the power off; then turn the power on again.       | Press the power switch over 3 seconds to reset the TM printer.                                                                                        |

### 6.1.2 Power Off Control by the Host

You can turn off the power of the TM printer from the application. When using the printer with the power switch disabled (DIP switch 1 on), turn off the printer by command before turning off the host. Power off control differs as follows according to the setting of the DIP switches.

#### 6.1.2.1 When the Power Switch is Enabled

The TM printer is powered off when the power off command is sent from the application.

#### 6.1.2.2 When the Power Switch is Disabled

When the power off command is sent from the application, the POWER LED of the TM printer flashes, and the printer waits for the system power to be turned off. ("[Error \(ERROR\) LED](#)" on page 109.)



**Note:**

*While the printer is executing the power off process, do not reset the printer.*

## 6.2 Head Divided Control

If a low capacity power supply is used, you can specify 2–4 head divided control and eliminate the power supply for part of the dots to save current consumption. (The default setting is 1 head divided control which supply power to all dots at the same time.)

Print speed is slower if you increase the number of divisions.

ESC/POS commands allow you to change head divided control while printing. You can keep print speed by using the divided printing only when printing a high density area such as a logo.

### **6.3 Control After Paper Cut**

When command control is used for printing, feed paper more than 1 mm {16/406"} immediately after paper cutting, and then stop feeding. 1 mm {16/406"} is equivalent to about 8 dots. If paper is left unfed after cutting, a paper jam may occur in the autocutter at the next paper feed.

### **6.4 NV Memory**

The NV Memory of the printer can be roughly divided into 3 parts.

- Firmware program area
- NV memory area for product information. User cannot edit.
- NV memory area that user can access.

The following items are in the NV memory that the user can access.

- a) Memory switches  
(Msw1, Msw2, Msw5\*, Msw8, Customize value such as the paper width and Serial communication conditions.)  
(\*: available only for TM-L90 other than 4\*\* models, TM-L90 Peeler other than 39\* models)
- b) User NV memory
- c) NV graphics memory
- d) User defined code page (Page 255 (space page))
- e) Area of command default values specified by users

By changing those values, you can customize your printer.

Note the following when writing to and erasing NV memory.

- ❑ The following restrictions apply when performing nonvolatile memory operations (including data store and delete).
  - The paper feed switch must not be used to feed paper.
  - No real time command can be executed.
  - The ASB status will not be sent, even when the ASB function in ESC/POS command is set to enable.
- ❑ The printer will sometimes enter the Busy state when data is being written to nonvolatile memory. It is important not to send data from the host computer while the printer is in the Busy state as it will be incapable of processing any received data.
- ❑ Frequent use of the functions for defining data to and deleting data from nonvolatile memory can damage the memory. As a rule, in using the various commands to write to NV memory, avoid writing more than an average of 10 times per day.

---

## **6.5 Customizing Printer**

You can customize your TM printer by changing memory switches and the command default value and saving the data onto the NV (nonvolatile) memory. Refer to the next section.

### **6.5.1 Printer Initial Setting Up**

Printer initial setting up can be made by memory switches and character code page. Refer to [page 42](#) for details of memory switches.

### **6.5.2 Changing Command Default Values**

You can customize your TM by changing the command default value and save the data onto the nonvolatile memory.

### **6.5.3 Using the NV Memory**

There is free area in NV memory for user can use. You can use this free area as memo, write other character information or multipurpose. The data is saved even if you turn off the power. Refer to the “ESC/POS Command Reference” on how to read and write.

---

## **6.6 Printer Status**

There are three ways to get the printer status, and each method has the following features. Refer to the “ESC/POS Command Reference” for details.

- **Automatic status (ASB):**  
When processed as a normal command, the printer automatically transmits a status message whenever the status changes. It is always necessary to check the ASB status.
- **Real time status:**  
When the printer receives this command, it responds with the specified printer status. Reporting the printer status takes priority over any normal print data.
- **Status:**  
The printer transmits a specified printer status in the same way that it processes normal print data.

## Chapter 7

---

# Handling

### 7.1 Maintenance

#### 7.1.1 Autocutter (TM-L90 only)

If label paper adhesive has stuck to the autocutter, it may dull the cutting edge. If the paper cannot be cut, contact your dealer or qualified service personnel.



*Adhesive adheres on cutter blade*

 **WARNING:**

*Do not touch the area beyond the cutter blade edge. To do so may lead to injury to your fingers.*

### 7.1.2 Print Head Cleaning

#### **CAUTION:**

The print head is very hot right after printing and is very dangerous. Be sure to allow the print head to cool down (after printing) before cleaning it. Also, be sure to turn off the printer power before cleaning the print head.

Paper dust on the heating elements may lower the print quality. In this case, clean the print head as follows.

1. Turn off the power.
2. Open the roll paper cover.
3. Clean the thermal elements of the print head using a cotton swab moistened with alcohol solvent (ethanol or isopropyl alcohol).

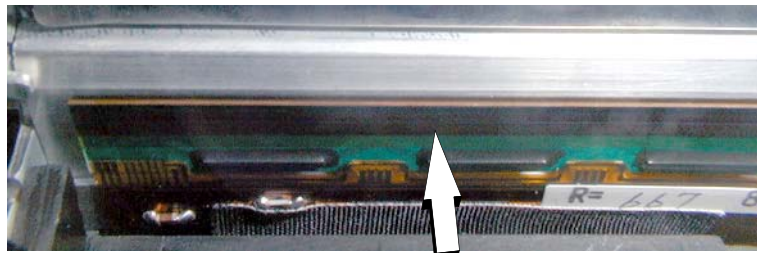

Print Head

#### **CAUTION:**

Do not touch the print head thermal elements with your bare hands. Doing so may have a bad effect on the head thermal elements due to the adhesion of dirt. Be careful not to scratch the print head when cleaning it.

4. Install roll paper and close the roll paper cover.  
For the method of inserting the roll paper, refer to ["Paper Loading Method" on page 53](#).
5. Close the roll paper cover.

#### **Note:**

Depending on the roll paper used, paper dust may stick to the platen roller and roll paper end sensor. To remove the paper dust, clean the platen roller and roll paper end sensor with a cotton swab moistened with water.

Epson recommends cleaning of the thermal head periodically (generally every three months) to maintain receipt print quality.

Keep pieces of metal away from contact with the head thermal elements and driver IC as they are extremely susceptible to damage.

If thermal paper contains Na, K, Cl or other ions, be sure to use the specified paper as ions may adversely affect the head thermal elements.

### **7.1.3 Cleaning the peeler (TM-L90 Peeler Model only)**

If label adhesive accumulates on the rollers of the peeler, remove it with the following procedure.

1. Pull the peeler open lever forward, and open the peeler cover.
2. Using a waste label or the like, remove the adhesive by dabbing the label on the roller.  
If it is left as it is, the adhesive may stick to an issued label.



3. After cleaning, close the peeler cover.

## 7.2 Troubleshooting

### 7.2.1 Panel LED and Error Status

#### 7.2.1.1 Power (POWER) LED

Power (POWER) LED

| Item      |                                  | Specifications        |
|-----------|----------------------------------|-----------------------|
| LED color |                                  | Green                 |
| On states | On                               | Power is supplied     |
|           | Off                              | Power is not supplied |
|           | Flashing with short intervals *1 | Execution in progress |
|           | Flashing with long intervals *1  | Powering down         |

\*1: Power (POWER) LED flashes according to the following patterns.

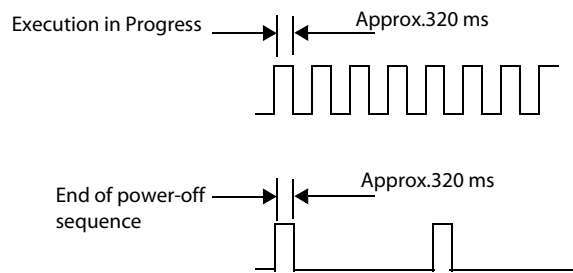

### 7.2.1.2 No Roll Paper (PAPER OUT) LED

| Item      |          | Specifications                                                                                                                                                                                                                                                                                                                                                                   |
|-----------|----------|----------------------------------------------------------------------------------------------------------------------------------------------------------------------------------------------------------------------------------------------------------------------------------------------------------------------------------------------------------------------------------|
| LED color |          | Red / Orange (TM-L90: 4** models)                                                                                                                                                                                                                                                                                                                                                |
| ON states | On       | Roll paper near end (only small amount of paper left on roll) or paper end (no paper left) detected                                                                                                                                                                                                                                                                              |
|           | Off      | Plenty of paper left on roll                                                                                                                                                                                                                                                                                                                                                     |
|           | Blinking | TM-L90: Waiting for self-test status, or waiting for macro execution status<br>TM-L90 Peeler Model: Waiting for self-test status, waiting for macro execution status, or waiting for label removal<br>After removing the issued label, if the PAPER OUT LED continues flashing, the label peeling sensor may be reacting to direct sunlight or the like. Press FEED button once. |

The PAPER OUT LED flashing pattern is as follows.

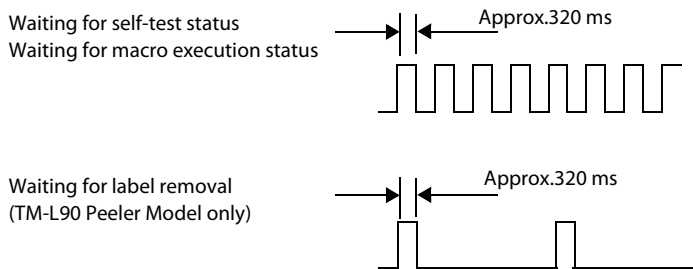

### 7.2.1.3 Error (ERROR) LED

Error (ERROR) LED

| Item      |          | Specifications                                                                                               |
|-----------|----------|--------------------------------------------------------------------------------------------------------------|
| LED color |          | Red / Orange (TM-L90: 4** models)                                                                            |
| ON states | On       | Offline (except during paper feeding using the FEED button and during test printing, and in the error state) |
|           | Off      | Normal condition                                                                                             |
|           | Blinking | Error state                                                                                                  |

 **Note:**

If an unrecoverable error occurs, turn the power off quickly.

When the error status occurs, stop all of the operations (printing, feeding, autocutting, drawer driving, etc.)

You may choose to make the printer status BUSY or not depending on the memory switch setting. (Refer to the "Memory Switch Settings" on page 42 and "Error Code" on page 110.)

### 7.2.1.4 Error Code

There are three types of error possible: Automatically Recoverable Errors, Recoverable Errors, and Unrecoverable Errors.

For the automatically recoverable errors, the users do not have to do anything special; instead it will recover automatically when the head temperature cools down or the cover is correctly closed.





For the recoverable errors, the user needs to perform some appropriate action suitable for the error to recover.

If an unrecoverable error occurs, printing is no longer possible. If the same error occurs again even after turning the power back on, contact qualified service personnel.

#### Automatically recoverable errors

Although normal printer operation is no longer possible when automatically recoverable errors occur, they do not represent printer failure. They are easily corrected through use of the printer's controls.

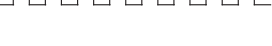
#### Automatically recoverable errors

| Error name                                                                | Type of error                                                              | Error LED flash code                                                                                                                                                                            | Recovery measure                                    |
|---------------------------------------------------------------------------|----------------------------------------------------------------------------|-------------------------------------------------------------------------------------------------------------------------------------------------------------------------------------------------|-----------------------------------------------------|
|                                                                           |                                                                            |                                                                                                               |                                                     |
| Roll paper cover open error (when the recoverable error is selected) (*1) | Printing on the roll paper is not performed correctly due to a cover-open. | LED ON → <br>LED OFF →   | Automatic recovery by closing the roll paper cover. |
| Print head temperature error (*2)                                         | The head has become very hot.                                              | LED ON → <br>LED OFF →  | Recovers automatically when the print head cools.   |



#### Note:





\*1 Use the memory switch Msw8-8 to determine the cover open error as an automatically recoverable error or a recoverable error. (Factory default setting is Recoverable Error.)

\*2 This is not any failure or abnormal condition; it just indicates an error condition in case the head temperature has become very hot due to the continuous use with heavy printing duty. If an abnormal value is detected because of the circuit, the printer judges it a drive circuit error and it becomes an unrecoverable error.

Recoverable errors

Although normal printer operation is no longer possible when recoverable errors occur, they do not represent printer failure. You can recover from a recoverable error by turning on the power switch or issuing a command from the driver after eliminating the cause.

Recoverable Errors

| Error name                          | Type of error                                                                                                                    | Error LED flash code<br> | Recovery operation                                                                                                                                                                                                                                                                                     |
|-------------------------------------|----------------------------------------------------------------------------------------------------------------------------------|------------------------------------------------------------------------------------------------------------|--------------------------------------------------------------------------------------------------------------------------------------------------------------------------------------------------------------------------------------------------------------------------------------------------------|
| Roll paper cover open error(*1)     | Printing on the roll paper is not performed correctly due to a cover-open.                                                       |                          | After having closed the cover, perform either A or B to recover.<br>A, Send the error recover command from the driver.<br>B, Turn on the power switch again.                                                                                                                                           |
| Autocutter error (TM-L90 only) (*2) | The autocutter does not work correctly.                                                                                          |                          | After having eliminated the cause of the error, perform either A or B to recover.<br>A, Send the error recover command from the driver.<br>B, Turn on the power switch again.                                                                                                                          |
| Paper layout error (*3)             | Cannot detect the label or the black mark.<br>The wrong type of the paper, which is not stored in the printer, is currently set. |                        | Perform either A or B to recover.<br>A, Install the same type of paper that is stored in the printer, and then send the error recover command from the driver or turn on the power switch again.<br>B, Turn off the power switch, and then reset the paper layout of the current paper in the printer. |

 **Note:**

- \*1: Use the memory switch Msw8-8 to determine the cover open error as an automatically recoverable error or a recoverable error. (Factory default setting is Recoverable Error.)
- \*2: With the TM-L90, if an autocutter error occurs due to a paper jam, turn off the power, remove the jammed paper, and turn the power on again.
- \*3: When a paper layout error occurs causing by jamming paper while printing, turn the power off and remove the jammed paper, then turn the power on again.  
You can easily set the paper layout by using the automatic paper layout setting. Refer to "Paper Loading Method" on page 53.

Error recover command is valid only when a recoverable error (excluding automatically recoverable errors) occurs. When a recoverable error occurs, you can recover from the error by sending an error recover command from the driver after eliminating the cause of the error; you do not need to turn on the power switch again.

How to send the error recover command from each of the drivers is as follows.

- ❑ OPOS ADK  
Either use the ClearOutput method or send the error recover command of ESC/POS to the printer.  
For more details, see the manual supplied with your OPOS.
- ❑ APD (Advanced Printer Driver)  
Send the error recover command of ESC/POS to the printer using ControlA font.  
For more details, see the manual supplied with your APD and the ESC/POS Command Reference.
- ❑ ESC/POS  
Send the error recover command to the printer  
For more details, see the ESC/POS Command Reference.



**Note:**

For details on how to obtain the ESC/POS Command Reference, see ["Introduction of Control Methods" on page 83](#).

Unrecoverable errors

Normal printer operation is no longer possible when unrecoverable errors occur. The printer may be out of order. If the same error occurs again even after turning the power back on, contact qualified service personnel.

**⚠ CAUTION:**

When an unrecoverable error occurs, turn off the power supply immediately. Unplug the AC cable from the printer when the power switch is invalid.





❑ TM-L90 unrecoverable errors

Unrecoverable Errors

| Error name                        | Type of error                                                        | Error LED flash code | Recovery measure       |
|-----------------------------------|----------------------------------------------------------------------|----------------------|------------------------|
|                                   |                                                                      |                      |                        |
| R/W error in memory               | After R/W checking, the printer does not work correctly.             |                      | Impossible to recover. |
| High voltage error                | The power supply voltage is extremely high.                          |                      | Impossible to recover. |
| Low voltage error                 | The power supply voltage is extremely low.                           |                      | Impossible to recover. |
| CPU execution error               | The CPU executes an incorrect address or I/F board is not connected. |                      | Impossible to recover. |
| Internal circuit connection error | Internal circuits are not connected correctly.                       |                      | Impossible to recover. |
| UIB error                         | An abnormal operation occurs in UIB.                                 |                      | Impossible to recover. |

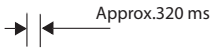
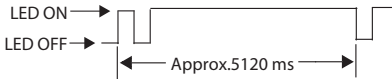
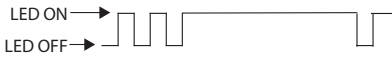
❑ TM-L90 Peeler Model unrecoverable errors

*Unrecoverable Errors*

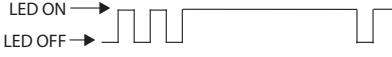
| Error name                        | Type of error                                                        | Error LED flash code<br> | Recovery measure       |
|-----------------------------------|----------------------------------------------------------------------|------------------------------------------------------------------------------------------------------------|------------------------|
| R/W error in memory               | After R/W checking, the printer does not work correctly.             |                          | Impossible to recover. |
| High voltage error                | The power supply voltage is extremely high.                          |                          | Impossible to recover. |
| Low voltage error                 | The power supply voltage is extremely low.                           |                          | Impossible to recover. |
| CPU execution error               | The CPU executes an incorrect address or I/F board is not connected. |                          | Impossible to recover. |
| Internal circuit connection error | Internal circuits are not connected correctly.                       |                         | Impossible to recover. |
| UIB error                         | An abnormal operation occurs in UIB.                                 |                        | Impossible to recover. |

### 7.2.2 The autocutter is jammed or the roll paper cover will not open (TM-L90 only)

1. Turn off the power.
2. Insert a flathead screwdriver into the groove shown in the figure, and push up the cover.

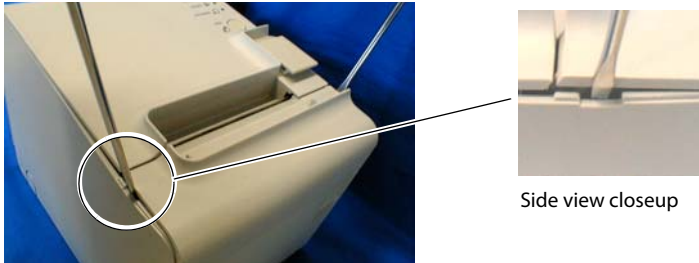

 **Note:**

*There is also a similar slot on the opposite side face. You can easily remove the cutter cover by lifting it while pushing the printer cover out from both sides simultaneously.*

3. Remove the cutter cover.

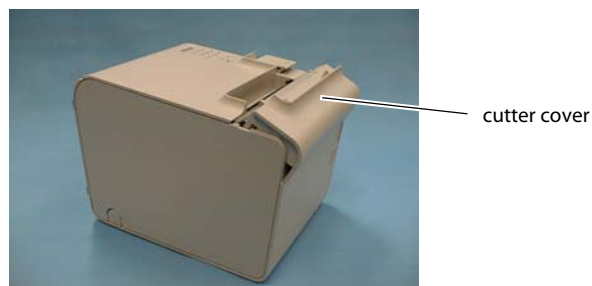

4. Use a ballpoint pen or tweezers to turn the knob in the direction of the arrow indicated until you see the triangle in the window.

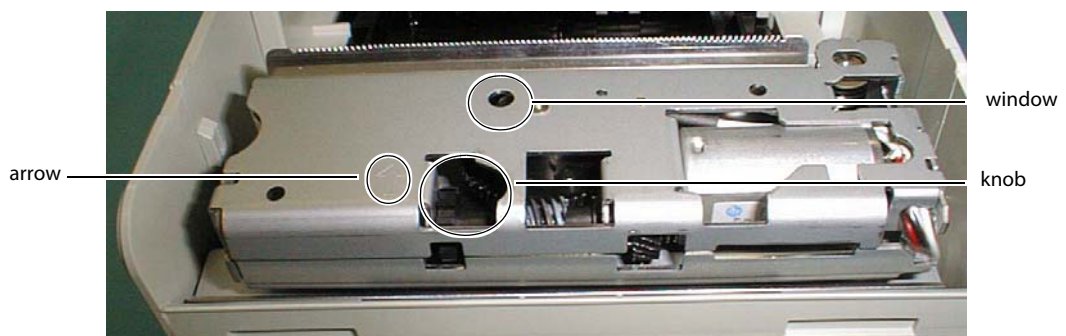

### **7.2.3 When a paper jam occurs (TM-L90 Peeler Model)**

1. Turn off the power.
2. Pull the peeler open lever forward, and open the peeler cover.
3. Pull the cover open lever, and open the roll paper cover.
4. Check for a paper jam, and remove the paper.
5. Insert the roll paper.

### **7.2.4 The printer became inoperative after you change the interface reset signal in the memory switch setting mode**

If you make a signal setting different from that of the connected interface while changing the interface reset signal in the memory switch setting mode, the printer may become inoperative (e.g. the FEED switch quits working).

In such a case, disconnect the connected cable to recover from the inoperative status temporarily. After that, set the interface reset signal again to meet your interface in the memory switch setting mode

### **7.3 Shipping Procedures**

Perform the following measures before shipping the printer.

1. Turn off the printer.
2. Check that the POWER LED is off.
3. Remove the power supply connectors.
4. Pack the printer, keeping it right-side-up.



## Appendix

### Setting items for Memory Switch Setting Mode

#### Setting items of TM-L90 4\*\* models

See "Memory Switch Settings" on page 42 for the procedures for the memory switch setting mode.

| Setting Items                |                       |                   | Options                                                                                    |
|------------------------------|-----------------------|-------------------|--------------------------------------------------------------------------------------------|
| 1st page                     | 2nd page              | 3rd page          | * The initial setting is underlined.                                                       |
| 1: Print Current Settings    |                       |                   | -                                                                                          |
| 2: Print Density             | 1: Monochrome         | 1: Density Sample | 70%, 75%, 80%, 85%, 90%, 95%, <u>100%</u> , 105%, 110%, 115%, 120%, 125%, 130%, 135%, 140% |
|                              |                       | 2: Density List   | 70%, 75%, 80%, 85%, 90%, 95%, <u>100%</u> , 105%, 110%, 115%, 120%, 125%, 130%, 135%, 140% |
|                              | 2: Multi-Tone         | 1: Density Sample | 70%, 75%, 80%, 85%, 90%, 95%, <u>100%</u> , 105%, 110%, 115%, 120%, 125%, 130%, 135%, 140% |
|                              |                       | 2: Density List   | 70%, 75%, 80%, 85%, 90%, 95%, <u>100%</u> , 105%, 110%, 115%, 120%, 125%, 130%, 135%, 140% |
| 3: Serial Interface Settings | 1: Baud Rate          |                   | 2400 bps, 4800 bps, 9600 bps, <u>19200 bps</u> , 38400 bps, 57600 bps, 115200 bps          |
|                              | 2: Parity             |                   | <u>None</u> , Odd, Even                                                                    |
|                              | 3: Handshaking        |                   | <u>DTR/DSR</u> , XON/XOFF                                                                  |
|                              | 4: Data Bits          |                   | 7 bits, <u>8 bits</u>                                                                      |
|                              | 5: Data Receive Error |                   | <u>Print "?"</u> , Ignored                                                                 |
| 4: Paper Width               |                       |                   | <u>80 mm</u> , 70 mm, 60 mm, 58 mm, 38 mm                                                  |

|                      |              |                                    |                                                                                                                                                                                                                                                                                                                                                                                               |
|----------------------|--------------|------------------------------------|-----------------------------------------------------------------------------------------------------------------------------------------------------------------------------------------------------------------------------------------------------------------------------------------------------------------------------------------------------------------------------------------------|
| 5: Default Character | 1: Code Page | 1: Western Europe, Southern Europe | <u>Page 0: PC437 (USA, Standard Europe)</u><br>Page 3: PC860 (Portuguese)<br>Page 11: PC851 (Greek)<br>Page 14: PC737 (Greek)<br>Page 15: ISO8859-7 (Greek)<br>Page 16: WPC1252<br>Page 18: PC852 (Latin 2)<br>Page 19: PC858<br>Page 34: PC855 (Cyrillic)<br>Page 38: PC869 (Greek)<br>Page 39: ISO8859-2 (Latin 2)<br>Page 40: ISO8859-15 (Latin 9)<br>Page 45: WPC1250<br>Page 47: WPC1253 |
|                      |              | 2: Eastern Europe, Northern Europe | Page 5: PC865 (Nordic)<br>Page 17: PC866 (Cyrillic #2)<br>Page 33: WPC775<br>Page 35: PC861 (Icelandic)<br>Page 42: PC1118 (Lithuanian)<br>Page 43: PW1119 (Lithuanian)<br>Page 44: PC1125 (Ukrainian)<br>Page 46: WPC1251<br>Page 51: WPC1257                                                                                                                                                |
|                      |              | 3: USA, Canada                     | Page 0: PC437 (USA, Standard Europe)<br>Page 4: PC863 (Canadian-French)                                                                                                                                                                                                                                                                                                                       |
|                      |              | 4: Asia                            | Page 1: Katakana<br>Page 20: KU42<br>Page 21: TIS11 (Thai)<br>Page 22: TIS13 (Thai)<br>Page 23: TIS14 (Thai)<br>Page 24: TIS16 (Thai)<br>Page 25: TIS17 (Thai)<br>Page 26: TIS18 (Thai)<br>Page 30: TCVN-3 (Vietnamese)<br>Page 31: TCVN-3 (Vietnamese)<br>Page 52: WPC1258<br>Page 53: KZ-1048 (Kazakhstan)                                                                                  |
|                      |              | 5: Turkey, Arabia                  | Page 12: PC853 (Turkish)<br>Page 13: PC857 (Turkish)<br>Page 32: PC720<br>Page 36: PC862 (Hebrew)<br>Page 37: PC864 (Arabic)<br>Page 41: PC1098 (Farsi)<br>Page 48: WPC1254<br>Page 49: WPC1255<br>Page 50: WPC1256                                                                                                                                                                           |
|                      |              | 6: Others                          | Page 2: PC850 (Multilingual)<br>Page 255: User Defined Page                                                                                                                                                                                                                                                                                                                                   |
|                      |              | 2: International Character Set     | 1: The Americas, Europe                                                                                                                                                                                                                                                                                                                                                                       |
|                      |              | 2: Asia, Arabia                    | Japan, Korea, China, Vietnam, Arabia                                                                                                                                                                                                                                                                                                                                                          |

|                              |                                                |                                                                               |
|------------------------------|------------------------------------------------|-------------------------------------------------------------------------------|
| 6: Embedded Font Replacement | 1: Font A Replacement                          | Font A (No Replacement), Font B                                               |
|                              | 2: Font B Replacement                          | Font A, <u>Font B (No Replacement)</u>                                        |
| 7: Interface Selection       |                                                | UIB, Built-in USB, <u>Auto</u>                                                |
| 8: USB Interface Settings    | 1: Class                                       | <u>Vendor Class</u> , Printer Class                                           |
|                              | 2: USB Power Saving                            | <u>Enabled</u> , Disabled                                                     |
| 9: Printing Speed            |                                                | Level 1 (Slow) - <u>Level 6</u> - Level 9 (Fast)                              |
| 10: Auto Cut                 |                                                | <u>Enable</u> , Disable                                                       |
| 11: Label Settings           | 1: Automatic measurement of maximum length     | <u>160 mm</u> , 300 mm                                                        |
|                              | 2: Moving to the print start position          | Disabled, <u>Enabled</u>                                                      |
| 12: Paper Feed Settings      | 1: Operation when print position misalignment  | <u>Move to next start position</u> , Does not move to next start position     |
|                              | 2: Operation select when layout error recovery | <u>Automatic measurement for paper</u> , Move to next printing start position |
|                              | 3: Auto cut after closing cover                | <u>Disable</u> , Enable                                                       |
|                              | 4: Feed length after closing cover             | 20 mm, <u>40 mm</u>                                                           |

|                    |                                      |                                              |                                                               |
|--------------------|--------------------------------------|----------------------------------------------|---------------------------------------------------------------|
| 13: Other Settings | 1: Buzzer Control                    | 1: Select Buzzer                             | <u>Internal Buzzer</u> , Option Buzzer, Buzzer Disable        |
|                    |                                      | 2: Buzzer Frequency (Error)                  | <u>Continuous</u> , 1 time, No sound                          |
|                    |                                      | 3: Sound Pattern (Auto cut)                  | <u>Pattern A</u> , Pattern B, Pattern C, Pattern D, Pattern E |
|                    |                                      | 4: Buzzer Frequency (Auto cut)               | <u>1 time</u> , No sound                                      |
|                    |                                      | 5: Sound Pattern (Pulse 1)                   | <u>Pattern A</u> , Pattern B, Pattern C, Pattern D, Pattern E |
|                    |                                      | 6: Buzzer Frequency (Pulse 1)                | 1 time, <u>No sound</u>                                       |
|                    |                                      | 7: Sound Pattern (Pulse 2)                   | Pattern A, <u>Pattern B</u> , Pattern C, Pattern D, Pattern E |
|                    |                                      | 8: Buzzer Frequency (Pulse 2)                | <u>1 time</u> , No sound                                      |
|                    | 2: Interface Settings                | 1: Receive Buffer Capacity                   | <u>4 KB</u> , 45 bytes                                        |
|                    |                                      | 2: BUSY Condition                            | <u>Receive Buffer Full or Offline</u> , Receive Buffer Full   |
|                    |                                      | 3: Auto Line Feed                            | <u>Always disabled</u> , Always enabled                       |
|                    |                                      | 4: State to cancel buffer BUSY               | <u>Not BUSY = 256 bytes</u> , Not BUSY = 138 bytes            |
|                    |                                      | 5: Error Signal                              | <u>Enabled</u> , Disabled                                     |
|                    | 3: Near-End LED                      | Disabled, <u>Enabled</u>                     |                                                               |
|                    | 4: Transmit the power ON information | <u>Does not transmit</u> , Transmit          |                                                               |
|                    | 5: Recovery layout error             | <u>DLE ENQ or Cover open/close</u> , DLE ENQ |                                                               |

**Setting items of TM-L90 other than 4\*\* models**

See "Memory Switch Settings" on page 42 for the procedures for the memory switch setting mode.

| Setting Items                      |               | Options                                                                                                                                                                                                                                                                                                                                                                                                                                                                                                      |
|------------------------------------|---------------|--------------------------------------------------------------------------------------------------------------------------------------------------------------------------------------------------------------------------------------------------------------------------------------------------------------------------------------------------------------------------------------------------------------------------------------------------------------------------------------------------------------|
| 1st page                           | 2nd page      | * The initial setting is underlined.                                                                                                                                                                                                                                                                                                                                                                                                                                                                         |
| 1: Auto Cutter                     |               | <u>Install</u> , Uninstalled                                                                                                                                                                                                                                                                                                                                                                                                                                                                                 |
| 2: Paper, Print Density            | 1: Monochrome | [Print density set up]<br>70%, 75%, 80%, 85%, 90%, 95%, <u>100%</u> , 105%, 110%, 115%,<br>120%, 125%, 130%, 135%, 140%                                                                                                                                                                                                                                                                                                                                                                                      |
|                                    | 2: Two color  | [Print density set up]<br>70%, 75%, 80%, 85%, 90%, 95%, <u>100%</u> , 105%, 110%, 115%,<br>120%, 125%, 130%, 135%, 140%                                                                                                                                                                                                                                                                                                                                                                                      |
| 3: Basic Serial Interface Settings |               | [Baud rate set up]<br>2400 bps, 4800 bps, 9600 bps, <u>19200 bps</u> , 38400 bps, 57600<br>bps, 115200 bps                                                                                                                                                                                                                                                                                                                                                                                                   |
|                                    |               | [Data bits / Handshaking / Parity set up]<br><u>8 bits / DTR/DSR / none</u><br>8 bits / DTR/DSR / even<br>8 bits / DTR/DSR / odd<br>8 bits / XON/XOFF / none<br>8 bits / XON/XOFF / even<br>8 bits / XON/XOFF / odd<br>7 bits / DTR/DSR / none<br>7 bits / DTR/DSR / even<br>7 bits / DTR/DSR / odd<br>7 bits / XON/XOFF / none<br>7 bits / XON/XOFF / even<br>7 bits / XON/XOFF / odd                                                                                                                       |
| 4: Advanced Interface Settings     |               | [Buffer Capacity / Receive Error / Handshaking Operation<br>(Busy Condition)]<br><u>4 Kbytes / prints '?' / Off-line or Receive buffer full</u><br>4 Kbytes / prints '?' / Receive buffer full<br>4 Kbytes / ignore / Off-line or Receive buffer full<br>4 Kbytes / ignore / Receive buffer full<br>45 bytes / prints '?' / Off-line or Receive buffer full<br>45 bytes / prints '?' / Receive buffer full<br>45 bytes / ignore / Off-line or Receive buffer full<br>45 bytes / ignore / Receive buffer full |
| 6: Interface Reset Signal          |               | [Serial #25 / Serial #6]<br><u>Disable / Disable</u><br>Disable / Enable<br>Enable / Disable<br>Enable / Enable                                                                                                                                                                                                                                                                                                                                                                                              |
| 7: Paper Width                     |               | 38 mm, 58 mm, 60 mm, 70 mm, <u>80 mm</u>                                                                                                                                                                                                                                                                                                                                                                                                                                                                     |

|                   |                                                                                                                              |
|-------------------|------------------------------------------------------------------------------------------------------------------------------|
| 8: Other settings | [Selection of the PAPER OUT LED status when a paper near-end is detected]<br><u>On</u> , Off                                 |
|                   | [Recovery selection when paper layout error occurs]<br><u>DLE ENQ or cover open/close</u><br>DLE ENQ                         |
| 11: Select label  | [Select automatic measurement of maximum length for paper]<br><u>160 mm</u> , 300 mm                                         |
|                   | [Select moving to the print starting position when power is turned on]<br><u>moves to starting position</u><br>does not move |

### Setting items of TM-L90 Peeler 39\* models

See "Memory Switch Settings" on page 42 for the procedures for the memory switch setting mode.

| Setting Items                |                       |                   | Options                                                                                    |
|------------------------------|-----------------------|-------------------|--------------------------------------------------------------------------------------------|
| 1st page                     | 2nd page              | 3rd page          | * The initial setting is underlined.                                                       |
| 1: Print Current Settings    |                       |                   | -                                                                                          |
| 2: Print Density             | 1: Monochrome         | 1: Density Sample | 70%, 75%, 80%, 85%, 90%, 95%, <u>100%</u> , 105%, 110%, 115%, 120%, 125%, 130%, 135%, 140% |
|                              |                       | 2: Density List   | 70%, 75%, 80%, 85%, 90%, 95%, <u>100%</u> , 105%, 110%, 115%, 120%, 125%, 130%, 135%, 140% |
| 3: Serial Interface Settings | 1: Baud Rate          |                   | 2400 bps, 4800 bps, 9600 bps, <u>19200 bps</u> , 38400 bps, 57600 bps, 115200 bps          |
|                              | 2: Parity             |                   | <u>None</u> , Odd, Even                                                                    |
|                              | 3: Handshaking        |                   | <u>DTR/DSR</u> , XON/XOFF                                                                  |
|                              | 4: Data Bits          |                   | 7 bits, <u>8 bits</u>                                                                      |
|                              | 5: Data Receive Error |                   | <u>Print "?"</u> , Ignored                                                                 |
| 4: Paper Width               |                       |                   | <u>80 mm</u> , 70 mm, 60 mm, 58 mm, 38 mm                                                  |

|                      |              |                                    |                                                                                                                                                                                                                                                                                                                                                                                                                                                                                                                                                                                                                                                                                                    |
|----------------------|--------------|------------------------------------|----------------------------------------------------------------------------------------------------------------------------------------------------------------------------------------------------------------------------------------------------------------------------------------------------------------------------------------------------------------------------------------------------------------------------------------------------------------------------------------------------------------------------------------------------------------------------------------------------------------------------------------------------------------------------------------------------|
| 5: Default Character | 1: Code Page | 1: Western Europe, Southern Europe | <p><u>Page 0: PC437 (USA, Standard Europe)</u><br/>                     Page 3: PC860 (Portuguese)<br/>                     Page 11: PC851 (Greek)<br/>                     Page 14: PC737 (Greek)<br/>                     Page 15: ISO8859-7 (Greek)<br/>                     Page 16: WPC1252<br/>                     Page 18: PC852 (Latin 2)<br/>                     Page 19: PC858<br/>                     Page 34: PC855 (Cyrillic)<br/>                     Page 38: PC869 (Greek)<br/>                     Page 39: ISO8859-2 (Latin 2)<br/>                     Page 40: ISO8859-15 (Latin 9)<br/>                     Page 45: WPC1250<br/>                     Page 47: WPC1253</p> |
|                      |              | 2: Eastern Europe, Northern Europe | <p>Page 5: PC865 (Nordic)<br/>                     Page 17: PC866 (Cyrillic #2)<br/>                     Page 33: WPC775<br/>                     Page 35: PC861 (Icelandic)<br/>                     Page 42: PC1118 (Lithuanian)<br/>                     Page 43: PW1119 (Lithuanian)<br/>                     Page 44: PC1125 (Ukrainian)<br/>                     Page 46: WPC1251<br/>                     Page 51: WPC1257</p>                                                                                                                                                                                                                                                              |
|                      |              | 3: USA, Canada                     | <p>Page 0: PC437 (USA, Standard Europe)<br/>                     Page 4: PC863 (Canadian-French)</p>                                                                                                                                                                                                                                                                                                                                                                                                                                                                                                                                                                                               |
|                      |              | 4: Asia                            | <p>Page 1: Katakana<br/>                     Page 20: KU42<br/>                     Page 21: TIS11 (Thai)<br/>                     Page 22: TIS13 (Thai)<br/>                     Page 23: TIS14 (Thai)<br/>                     Page 24: TIS16 (Thai)<br/>                     Page 25: TIS17 (Thai)<br/>                     Page 26: TIS18 (Thai)<br/>                     Page 30: TCVN-3 (Vietnamese)<br/>                     Page 31: TCVN-3 (Vietnamese)<br/>                     Page 52: WPC1258<br/>                     Page 53: KZ-1048 (Kazakhstan)</p>                                                                                                                              |
|                      |              | 5: Turkey, Arabia, Israel          | <p>Page 12: PC853 (Turkish)<br/>                     Page 13: PC857 (Turkish)<br/>                     Page 32: PC720<br/>                     Page 36: PC862 (Hebrew)<br/>                     Page 37: PC864 (Arabic)<br/>                     Page 41: PC1098 (Farsi)<br/>                     Page 48: WPC1254<br/>                     Page 49: WPC1255<br/>                     Page 50: WPC1256</p>                                                                                                                                                                                                                                                                                         |
|                      |              | 6: Others                          | <p>Page 2: PC850 (Multilingual)<br/>                     Page 255: User Defined Page</p>                                                                                                                                                                                                                                                                                                                                                                                                                                                                                                                                                                                                           |
|                      |              | 2: International Character Set     | 1: The Americas, Europe                                                                                                                                                                                                                                                                                                                                                                                                                                                                                                                                                                                                                                                                            |
|                      |              | 2: Asia, Arabia                    | Japan, Korea, China, Vietnam, Arabia                                                                                                                                                                                                                                                                                                                                                                                                                                                                                                                                                                                                                                                               |

|                           |                                                          |                                                                                                                                                                   |                                                             |
|---------------------------|----------------------------------------------------------|-------------------------------------------------------------------------------------------------------------------------------------------------------------------|-------------------------------------------------------------|
| 8: USB Interface Settings | 1: Class                                                 | Vendor Class, Printer Class                                                                                                                                       |                                                             |
|                           | 2: USB Power Saving                                      | <u>Enabled</u> , Disabled                                                                                                                                         |                                                             |
| 9: Printing Speed         |                                                          | Level 1 (Slow) - <u>Level 6</u> - Level 9 (Fast)                                                                                                                  |                                                             |
| 11: Label Settings        | 1: Automatic measurement of maximum length               | <u>160 mm</u> , 300 mm                                                                                                                                            |                                                             |
|                           | 2: Moving to the print start position                    | <u>Disabled</u> , Enabled                                                                                                                                         |                                                             |
| 12: Paper Feed Settings   | 5: Select manual feed operation in Continuous issue mode | <u>Paper feed to the print starting position</u> , Paper feed to the peel position                                                                                |                                                             |
| 13: Other Settings        | 2: Interface Settings                                    | 1: Receive Buffer Capacity                                                                                                                                        | <u>4 KB</u> , 45 bytes                                      |
|                           |                                                          | 2: BUSY Condition                                                                                                                                                 | <u>Receive Buffer Full or Offline</u> , Receive Buffer Full |
|                           |                                                          | 3: Auto Line Feed                                                                                                                                                 | <u>Always disabled</u> , Always enabled                     |
|                           |                                                          | 4: State to cancel buffer BUSY                                                                                                                                    | <u>Not BUSY = 256 bytes</u> , Not BUSY = 138 bytes          |
|                           |                                                          | 5: Error Signal                                                                                                                                                   | <u>Enabled</u> , Disabled                                   |
|                           | 3: Near-End LED                                          | Disabled, <u>Enabled</u>                                                                                                                                          |                                                             |
|                           | 4: Transmit the power ON information                     | <u>Does not transmit</u> , Transmit                                                                                                                               |                                                             |
|                           | 5: Recovery layout error                                 | DLE ENQ<br>DLE ENQ or Main cover open/close<br><u>DLE ENQ or press down PAPER FEED button</u><br>DLE ENQ or Main cover open/close or press down PAPER FEED button |                                                             |

### Setting items of TM-L90 Peeler other than 39\* models

See "[Memory Switch Settings](#)" on page 42 for the procedures for the memory switch setting mode.

| Setting Items           |               | Options                                                                                                              |
|-------------------------|---------------|----------------------------------------------------------------------------------------------------------------------|
| 1st page                | 2nd page      | * The initial setting is underlined.                                                                                 |
| 2: Paper, Print Density | 1: Monochrome | [Print density set up]<br>70%, 75%, 80%, 85%, 90%, 95%, <u>100%</u> , 105%, 110%, 115%, 120%, 125%, 130%, 135%, 140% |
|                         | 2: Two color  | [Print density set up]<br>70%, 75%, 80%, 85%, 90%, 95%, <u>100%</u> , 105%, 110%, 115%, 120%, 125%, 130%, 135%, 140% |

|                                           |                                                                                                                                                                                                                                                                                                                                                                                                                                                                                                                          |
|-------------------------------------------|--------------------------------------------------------------------------------------------------------------------------------------------------------------------------------------------------------------------------------------------------------------------------------------------------------------------------------------------------------------------------------------------------------------------------------------------------------------------------------------------------------------------------|
| <p>3: Basic Serial Interface Settings</p> | <p>[Baud rate set up]<br/>2400 bps, 4800 bps, 9600 bps, <u>19200 bps</u>, 38400 bps, 57600 bps, 115200 bps</p> <p>[Data bits / Handshaking / Parity set up]<br/><u>8 bits / DTR/DSR / none</u><br/>8 bits / DTR/DSR / even<br/>8 bits / DTR/DSR / odd<br/>8 bits / XON/XOFF / none<br/>8 bits / XON/XOFF / even<br/>8 bits / XON/XOFF / odd<br/>7 bits / DTR/DSR / none<br/>7 bits / DTR/DSR / even<br/>7 bits / DTR/DSR / odd<br/>7 bits / XON/XOFF / none<br/>7 bits / XON/XOFF / even<br/>7 bits / XON/XOFF / odd</p> |
| <p>4: Advanced Interface Settings</p>     | <p>[Buffer Capacity / Receive Error / Handshaking Operation (Busy Condition)]<br/><u>4 Kbytes / prints '?' / Off-line or Receive buffer full</u><br/>4 Kbytes / prints '?' / Receive buffer full<br/>4 Kbytes / ignore / Off-line or Receive buffer full<br/>4 Kbytes / ignore / Receive buffer full<br/>45 bytes / prints '?' / Off-line or Receive buffer full<br/>45 bytes / prints '?' / Receive buffer full<br/>45 bytes / ignore / Off-line or Receive buffer full<br/>45 bytes / ignore / Receive buffer full</p> |
| <p>6: Interface Reset Signal</p>          | <p>[Serial #25 / Serial #6]<br/><u>Disable / Disable</u><br/>Disable / Enable<br/>Enable / Disable<br/>Enable / Enable</p>                                                                                                                                                                                                                                                                                                                                                                                               |
| <p>7: Paper Width</p>                     | <p>38 mm, 58 mm, 60 mm, 70 mm, <u>80 mm</u></p>                                                                                                                                                                                                                                                                                                                                                                                                                                                                          |
| <p>8: Other settings 1</p>                | <p>[Selection of the PAPER OUT LED status when a paper near-end is detected]<br/><u>On</u>, Off</p> <p>[Recovery selection when paper layout error occurs]<br/>DLE ENQ<br/>DLE ENQ or Main cover open/close<br/><u>DLE ENQ or press down PAPER FEED button</u><br/>DLE ENQ or Main cover open/close or press down PAPER FEED button</p>                                                                                                                                                                                  |
| <p>9: Other settings 2</p>                | <p>[Select manual feed operation]<br/><u>Paper feed to the print starting position</u><br/>Paper feed to the peel position</p>                                                                                                                                                                                                                                                                                                                                                                                           |
| <p>11: Select label</p>                   | <p>[Select automatic measurement of maximum length for paper]<br/><u>160 mm</u>, 300 mm</p> <p>[Select moving to the print starting position when power is turned on]<br/>moves to starting position<br/><u>does not move</u></p>                                                                                                                                                                                                                                                                                        |

## Product Specifications

### Product Specifications

#### TM-L90

|                                                          | 4** models                                                                                                                                                                                                                                                                                   | Other than 4** models                                                                                            |
|----------------------------------------------------------|----------------------------------------------------------------------------------------------------------------------------------------------------------------------------------------------------------------------------------------------------------------------------------------------|------------------------------------------------------------------------------------------------------------------|
| <b>Print method</b>                                      | Thermal line, 8 × 8 dots/mm (203 × 203 dpi)                                                                                                                                                                                                                                                  |                                                                                                                  |
| <b>Print width</b>                                       | 80 mm (factory setting) or 38 to 70 mm can be set using a roll paper spacer                                                                                                                                                                                                                  |                                                                                                                  |
| <b>Cutting method</b>                                    | Separated-blade scissor                                                                                                                                                                                                                                                                      |                                                                                                                  |
| <b>Cut type</b>                                          | Users can choose from the following two types.<br><input type="checkbox"/> Full cut (cuts paper completely) (default setting)<br><input type="checkbox"/> Partial cut (one point left uncut) is also available as a dealer option.<br>(Set by changing the position of the autocutter unit.) |                                                                                                                  |
| <b>Possible thickness to be cut with a manual cutter</b> | 100 mm or less                                                                                                                                                                                                                                                                               |                                                                                                                  |
| <b>Character sets</b>                                    | 95 alphanumeric, 18 international character sets, Extended graphics 128 × 47 pages (including user-defined page)                                                                                                                                                                             | 95 alphanumeric, 14 international character sets, Extended graphics 128 × 11 pages (including user-defined page) |
| <b>Interface (compatible)</b>                            | RS-232C, Parallel, USB, Ethernet (10Base T/100Base TX), Wireless LAN (IEEE802.11 a/b/g/n)                                                                                                                                                                                                    | RS-232C, Parallel, USB, Ethernet (10Base T), Wireless LAN (IEEE802.11b)                                          |
| <b>Buffer</b>                                            | Receive buffer: 4 KB/45 bytes                                                                                                                                                                                                                                                                |                                                                                                                  |
|                                                          | User-defined buffer<br>Downloaded bit image:      Approximately 12 KB<br>(common for all models)<br>User-defined characters:    Approximately 11 KB<br>(for ANK/Multilingual model)<br>Approximately 15 KB<br>(for Japanese model)                                                           |                                                                                                                  |
|                                                          | Download graphics memory: 208 KB                                                                                                                                                                                                                                                             | --                                                                                                               |
|                                                          | Macro buffer: 2 KB                                                                                                                                                                                                                                                                           |                                                                                                                  |
|                                                          | Non-volatile graphics data buffer: 384 KB maximum<br>User NV memory: 192 KB maximum<br>Note) The combination of NV graphics data buffer and user NV memory is determined by the memory switch.                                                                                               |                                                                                                                  |
|                                                          | Page mode area: 103 KB                                                                                                                                                                                                                                                                       |                                                                                                                  |
|                                                          |                                                                                                                                                                                                                                                                                              |                                                                                                                  |
| <b>D.K.D. function</b>                                   | 2 drives                                                                                                                                                                                                                                                                                     |                                                                                                                  |
| <b>Power Supply</b>                                      | Power supplied by AC adapter PS-180/PS-190 (option)                                                                                                                                                                                                                                          |                                                                                                                  |
| <b>Operating Voltage</b>                                 | DC 24 V±7%                                                                                                                                                                                                                                                                                   |                                                                                                                  |
| <b>Current consumption</b>                               | Average: Approximately 1.8 A (Character font A, a-N, 36-character rolling pattern, full-column printing)                                                                                                                                                                                     | Average: Approximately 1.7 A (Character font A, a-N, 36-character rolling pattern, full-column printing)         |
|                                                          |                                                                                                                                                                                                                                                                                              | Peak:            Approximately 7.7 A<br>Standby:       Approximately 0.1 A                                       |

|                      |                                                                          |
|----------------------|--------------------------------------------------------------------------|
| <b>Temperature</b>   | Operating: 5 to 45°C {41 to 113°F}<br>Storage: -10 to 50°C {14 to 122°F} |
| <b>Humidity</b>      | 10 to 90%                                                                |
| <b>Weight (mass)</b> | Approximately 1.9 kg {4.19 lb}                                           |



**Note:**

Install the paper exit guide packed in the box with the printer when the autocutter is used with a full cut, positioning the printer horizontally. If the printer is installed horizontally without the paper exit guide and the autocutter full cut is used, a cut sheet may drop in the paper path and it may cause a double-cut, paper jam, or autocutter error. However, if the printer is installed vertically or if the autocutter is used with a partial cut, the paper exit guide does not have to be used.

Refer to "[Instructions for Installation](#)" on page 23 for information on how to attach the paper exit guide.

Partial cut or full cut is not controlled by a software command.

When using die-cut labels, use care to cut between the labels.

The manual cutter in the autocutter unit is used to cut the receipt (paper thickness: approximately 75 µm) manually.

The cutting type (partial cut or full cut) must be selected before the printer is first used. If the cutting type is changed from partial cut to full cut after the printer has been used, the printer may not be reliable because the wear-out level of the cutter blade differs.

When leaving paper loaded for an extended period of time, make sure you feed about 30 mm of paper. This can prevent paper from wrinkling and causing prints to be too light.

## TM-L90 Peeler Model

|                                                            | 39* models                                                                                                                                                                                                        | Other than 39* models                                                                                                                                                |
|------------------------------------------------------------|-------------------------------------------------------------------------------------------------------------------------------------------------------------------------------------------------------------------|----------------------------------------------------------------------------------------------------------------------------------------------------------------------|
| <b>Print method</b>                                        | Thermal line, 8 × 8 dots/mm (203 × 203 dpi)                                                                                                                                                                       |                                                                                                                                                                      |
| <b>Print width</b>                                         | 80 mm (factory setting) or 38 to 70 mm can be set using a roll paper spacer                                                                                                                                       |                                                                                                                                                                      |
| <b>Manual cutter specification</b>                         | With continuous issuing, it is possible to cut the paper by hand                                                                                                                                                  |                                                                                                                                                                      |
| <b>Possible thickness to be cut with the manual cutter</b> | 100 mm or less                                                                                                                                                                                                    |                                                                                                                                                                      |
| <b>Character sets</b>                                      | 95 alphanumeric, 18 international character sets, Extended graphics 128 × 47 pages (including user-defined page)                                                                                                  | 95 alphanumeric, 14 international character sets, Extended graphics 128 × 11 pages (including user-defined page)                                                     |
| <b>Interface (compatible)</b>                              | RS-232C, Parallel, USB, Ethernet (10Base-T/100Base-TX), Wireless LAN(IEEE802.11a/b/g/n)                                                                                                                           | RS-232C, Parallel<br>Dealer option:<br>USB, Ethernet (10Base-T), Wireless LAN (IEEE802.11b)                                                                          |
| <b>Buffer</b>                                              | Receive buffer: 4 KB / 45 bytes                                                                                                                                                                                   |                                                                                                                                                                      |
|                                                            | User-defined buffer<br>Downloaded bit image: Approximately 12 KB (common for all models)<br>User-defined characters: Approximately 11 KB (for ANK/Multilingual model)<br>Approximately 15 KB (for Japanese model) |                                                                                                                                                                      |
|                                                            | Download graphics memory: 208 KB                                                                                                                                                                                  | --                                                                                                                                                                   |
|                                                            | Macro buffer: 2 KB                                                                                                                                                                                                |                                                                                                                                                                      |
|                                                            | Non-volatile graphics data buffer: 384 KB maximum<br>User NV memory: 192 KB maximum<br><b>Note:</b><br><i>The combination of NV graphics data buffer and user NV memory is determined by the memory switch.</i>   |                                                                                                                                                                      |
|                                                            | Page mode area: 103 KB                                                                                                                                                                                            |                                                                                                                                                                      |
| <b>D.K.D. function</b>                                     | 2 drives                                                                                                                                                                                                          |                                                                                                                                                                      |
| <b>Power Supply</b>                                        | Power supplied by AC adapter PS-180/PS-190 (option)                                                                                                                                                               |                                                                                                                                                                      |
| <b>Operating Voltage</b>                                   | DC 24 V±7%                                                                                                                                                                                                        |                                                                                                                                                                      |
| <b>Current consumption</b>                                 | Average: Approximately 1.8 A (Character font A, a-N, 36-character rolling pattern, fullcolumn printing)                                                                                                           | Average: Approximately 1.7 A (Character font A, a-N, 36-character rolling pattern, fullcolumn printing)<br>Peak: Approximately 7.7 A<br>Standby: Approximately 0.1 A |
| <b>Temperature</b>                                         | Operating: 5 to 45°C {41 to 113°F}<br>Storage: -10 to 50°C {14 to 122°F}                                                                                                                                          |                                                                                                                                                                      |
| <b>Humidity</b>                                            | 10 to 90%                                                                                                                                                                                                         |                                                                                                                                                                      |
| <b>Weight (mass)</b>                                       | Approximately 1.9 kg {4.19 lb}                                                                                                                                                                                    |                                                                                                                                                                      |



### Note:

When leaving paper loaded for an extended period of time, make sure you feed about 30 mm of paper. This can prevent paper from wrinkling and causing prints to be too light.

**Print Specifications**

| Item                         | Specifications                                                                                                                                                                                                                                                                                                                                                                                                                                  |                                                 |
|------------------------------|-------------------------------------------------------------------------------------------------------------------------------------------------------------------------------------------------------------------------------------------------------------------------------------------------------------------------------------------------------------------------------------------------------------------------------------------------|-------------------------------------------------|
| Printing method              | Thermal line printing                                                                                                                                                                                                                                                                                                                                                                                                                           |                                                 |
| Dot density                  | 0.125 × 0.125 mm/dot (203 × 203 dpi)<br>(dpi: dots per 25.4 mm {1"})                                                                                                                                                                                                                                                                                                                                                                            |                                                 |
| Printing direction           | Unidirectional with friction feed                                                                                                                                                                                                                                                                                                                                                                                                               |                                                 |
| Paper width                  | 80 mm (79.5±0.5 mm) (default setting)<br>It is possible to set optional positions in the range of 38 to 70 mm {1.50 to 2.76"}. The range of 71 to 79 mm {2.80 to 3.11"} cannot be set.                                                                                                                                                                                                                                                          |                                                 |
| Maximum printable area       | 72 mm {2.83"}, 576 dot positions<br>(when the paper width is 80 mm)                                                                                                                                                                                                                                                                                                                                                                             |                                                 |
| Characters per line          | Font                                                                                                                                                                                                                                                                                                                                                                                                                                            | Characters per line<br>(with 80 mm paper width) |
|                              | Font A 12 × 24                                                                                                                                                                                                                                                                                                                                                                                                                                  | 48                                              |
|                              | Font B 9 × 17                                                                                                                                                                                                                                                                                                                                                                                                                                   | 64                                              |
|                              | Kanji 24 × 24                                                                                                                                                                                                                                                                                                                                                                                                                                   | 24                                              |
|                              | Kanji 20 × 24                                                                                                                                                                                                                                                                                                                                                                                                                                   | 28                                              |
|                              | Kanji 16 × 16                                                                                                                                                                                                                                                                                                                                                                                                                                   | 36                                              |
| (Default setting is font A.) |                                                                                                                                                                                                                                                                                                                                                                                                                                                 |                                                 |
| Print Speed                  | <Normal printing> (default setting)<br>120 mm/s {4.72"} maximum<br><High speed printing> (selected with the memory switch)<br>150 mm/s {5.91"} maximum<br>(The high speed printing can be selected when the specified paper is used.)<br><Ladder barcode, two-dimensional code printing><br>90 mm/s {2.76"} maximum<br><Multi-tone graphics printing*> (only supported with APD)<br>120 mm/s {3.54"} maximum (*: available only for 4** models) |                                                 |
| Carriage return width        | 3.75 mm {0.15"}<br>Programmable by control command.                                                                                                                                                                                                                                                                                                                                                                                             |                                                 |

**Note:**

The print speed listed above is the value when the printer prints with the default print density level at 24 V and 25°C. The print speed may be changed automatically with the condition of the supply voltage or the head temperature.

Printing speed may be slower depending on the data transmission speed and the combination of control commands.

There might be a blank feed of a 10-dot line at the maximum before printing because printing of ladder bar codes and 2-D symbols only starts after reaching the specified speed.

## Reliability

### TM-L90

|                      |                                                                                                                                                                                                                                                                                                          |                                                                                                                                                                                                                                                                                                                                                                                                                                                                        |
|----------------------|----------------------------------------------------------------------------------------------------------------------------------------------------------------------------------------------------------------------------------------------------------------------------------------------------------|------------------------------------------------------------------------------------------------------------------------------------------------------------------------------------------------------------------------------------------------------------------------------------------------------------------------------------------------------------------------------------------------------------------------------------------------------------------------|
| Life* <sup>1</sup>   | When printing labels                                                                                                                                                                                                                                                                                     | 1,000,000 labels issued<br>(When the length of the label in the paper feeding direction is 25.4 mm {1"} through 63.5 mm {2.5"}). The value above corresponds to approximately 30 km to 70 km {18.64 to 43.5 miles} of running length. When printing labels whose length exceeds 63.5 mm, the label-issuing life is 70 km {43.5 miles} of running length.)<br>DTM9502 (only for 4** models): 700,000 labels issued (1,000,000 labels issued after cleaning the platen.) |
|                      | When issuing receipts (thickness type)                                                                                                                                                                                                                                                                   | 10,000,000 lines printed (3.75 mm {0.15"} for one line)<br>(The value above is calculated based on the printer using 15-line feeding and 10-line printing repeatedly with a 145 µm paper thickness. The value above corresponds to approximately 60 km {37.28 miles} of running length.)                                                                                                                                                                               |
|                      | When printing receipts                                                                                                                                                                                                                                                                                   | 20,000,000 lines printed (3.75 mm {0.15"} for one line)<br>(The value above is calculated based on the printer using 15-line feeding and 10-line printing repeatedly with 75 µm of paper thickness. The value above corresponds to approximately 120 km {74.57 miles} of running length.)                                                                                                                                                                              |
|                      | Thermal head                                                                                                                                                                                                                                                                                             | 150 million pulses                                                                                                                                                                                                                                                                                                                                                                                                                                                     |
|                      | Autocutter                                                                                                                                                                                                                                                                                               | When cutting receipts:<br>2,000,000 cuts (except for KF50, when the paper thickness is less than 75 µm)<br>1,200,000 cuts (for KF50 (KANZAN))<br>1,000,000 cuts (when the paper thickness is more than 75 µm and less than 145 µm)<br>When cutting labels:<br>1,000,000 cuts (Cutting between the labels)<br>500,000 cuts (Cutting continuous labels)                                                                                                                  |
| MTBF* <sup>2</sup>   | 360,000 hours<br>(when printing receipts with the ENTPD series)                                                                                                                                                                                                                                          |                                                                                                                                                                                                                                                                                                                                                                                                                                                                        |
| MCBF* <sup>3</sup>   | 70,000,000 lines printed<br>(when printing receipts with the ENTPD series.)                                                                                                                                                                                                                              |                                                                                                                                                                                                                                                                                                                                                                                                                                                                        |
| Vibration resistance | When packed: Frequency: 5 to 55 Hz<br>Acceleration: Approximately 19.6 m/s <sup>2</sup> {2 G}<br>Sweep: 10 minutes (half cycle)<br>Duration: 1 hour<br>Directions: x, y, and z<br><br>There is no external or internal visible damage and the unit operates normally after being subjected to vibration. |                                                                                                                                                                                                                                                                                                                                                                                                                                                                        |

|                            |                                                                                                                                                                                                                                                                                                                                                                                                                                                                                                                  |
|----------------------------|------------------------------------------------------------------------------------------------------------------------------------------------------------------------------------------------------------------------------------------------------------------------------------------------------------------------------------------------------------------------------------------------------------------------------------------------------------------------------------------------------------------|
| Impact resistance          | <p>When packed: Package: Epson standard package<br/>         Height: 60 cm {23.62"}<br/>         Directions: 1 corner, 3 edges, and 6 surfaces</p> <p>There is no external or internal visible damage and the unit operates normally after being dropped.</p> <p>When unpacked: Height: 5 cm {1.97"}<br/>         Directions: Lift one edge and release it (for all 4 edges).</p> <p>There is no external or internal visible damage and the unit operates normally after being dropped while not operating.</p> |
| Acoustic noise (operating) | <p>Approximately 53 dB (ANSI bystander position)</p> <p>Note: The value as shown above is measured when the Epson evaluation printing pattern is used. This value may be different, depending on the paper to be printed, the print duty, or the print conditions, such as the print speed or the print density.</p>                                                                                                                                                                                             |

\*1: Indicates the point at which the wear-out failure period starts.

\*2: Indicates the mean time between failures during the random failure period.

\*3: Indicates the overall mean time between failures, including wear-out and random failures, before the life is reached.

The values in the above table are based on use of Epson specified paper.

**TM-L90 Peeler Model**

|                            |              |                                                                                                                                                                                                                                                                                                                                                                                                                                                                         |
|----------------------------|--------------|-------------------------------------------------------------------------------------------------------------------------------------------------------------------------------------------------------------------------------------------------------------------------------------------------------------------------------------------------------------------------------------------------------------------------------------------------------------------------|
| Life* <sup>1</sup>         | Labels       | Issues 1,000,000 labels<br>(With feed direction label length of 25.4 {1 inch} to 63.5 mm {2.5 inch}).<br>Equivalent to a travel distance of about 30 to 70 km. When printing labels in excess of 63.5 mm, product lifetime in number of labels comes after a travel distance of 70 km)                                                                                                                                                                                  |
|                            | Receipts     | 20,000,000 lines printed (with 1 line at 3.75 mm)<br>(Assuming repeated printing of 10 lines with paper thickness of 75 μm or less and 15 line feed. Equivalent to a travel distance of about 120 km)                                                                                                                                                                                                                                                                   |
|                            | Thermal head | 150 million pulses                                                                                                                                                                                                                                                                                                                                                                                                                                                      |
| MTBF* <sup>2</sup>         |              | 360,000 hours                                                                                                                                                                                                                                                                                                                                                                                                                                                           |
| MCBF* <sup>3</sup>         |              | 70,000,000 lines printed                                                                                                                                                                                                                                                                                                                                                                                                                                                |
| Vibration resistance       |              | When packed: Frequency: 5 to 55 Hz<br>Acceleration: Approximately 19.6 m/s <sup>2</sup> {2 G}<br>Sweep: 10 minutes (half cycle)<br>Duration: 1 hour<br>Directions: x, y, and z<br><br>There is no external or internal visible damage and the unit operates normally after being subjected to vibration.                                                                                                                                                                |
| Impact resistance          |              | When packed: Package: Epson standard package<br>Height: 60 cm {23.62"}<br>Directions: 1 corner, 3 edges, and 6 surfaces<br><br>There is no external or internal visible damage and the unit operates normally after being dropped.<br>When unpacked: Height: 5 cm {1.97"}<br>Directions: Lift one edge and release it (for all 4 edges).<br><br>There is no external or internal visible damage and the unit operates normally after being dropped while not operating. |
| Acoustic noise (operating) |              | Approximately 53 dB (ANSI bystander position)<br>NOTE: The value as shown above is measured when the Epson evaluation printing pattern is used. This value may be different, depending on the paper to be printed, the print duty, or the print conditions, such as the print speed or the print density.                                                                                                                                                               |

\*1: Indicates the point at which the wear-out failure period starts.

\*2: Indicates the mean time between failures during the random failure period.

\*3: Indicates the overall mean time between failures, including wear-out and random failures, before the life is reached.

The values in the above table are based on use of Epson specified paper.

Depending on the paper, paper dust and adhesive may stick to the platen, head, and peeler unit.

## Character Specifications

### Character Specifications

| Item                    |                     | Specifications                                                                                                                                                                                                                                                                                                                                                                                                                                                                 |                                                                   |
|-------------------------|---------------------|--------------------------------------------------------------------------------------------------------------------------------------------------------------------------------------------------------------------------------------------------------------------------------------------------------------------------------------------------------------------------------------------------------------------------------------------------------------------------------|-------------------------------------------------------------------|
|                         |                     | TM-L90 4** models, TM-L90 Peeler 39* models                                                                                                                                                                                                                                                                                                                                                                                                                                    | TM-L90 other than 4** models, TM-L90 Peeler other than 39* models |
| Character type          | Alphanumeric        | 95 characters                                                                                                                                                                                                                                                                                                                                                                                                                                                                  |                                                                   |
|                         | International       | 18 sets                                                                                                                                                                                                                                                                                                                                                                                                                                                                        | 14 sets                                                           |
|                         | Extended graphics   | 128 characters × 47 pages<br>(including user-defined page)                                                                                                                                                                                                                                                                                                                                                                                                                     | 128 characters × 11 pages<br>(including user-defined page)        |
|                         | JIS (JISX0208-1990) | 6879 characters                                                                                                                                                                                                                                                                                                                                                                                                                                                                |                                                                   |
|                         | Special font        | 845 characters<br><br><div style="display: flex; justify-content: space-around;"> <div style="text-align: left;">                     JIS code<br/>                     2D-21 to 2D-7E<br/>                     79-21 to 7C-7E                 </div> <div style="text-align: left;">                     Shift JIS code<br/>                     87-40 to 87-9D<br/>                     ED-40 to EE-FC<br/>                     FA-40 to FC-4E                 </div> </div> |                                                                   |
| Character configuration |                     | See "Character Configurations and Dimensions" table. (Default is Font A.)                                                                                                                                                                                                                                                                                                                                                                                                      |                                                                   |
| Character dimensions    |                     | See "Character Configurations and Dimensions" table. (Spaces between characters not included.)                                                                                                                                                                                                                                                                                                                                                                                 |                                                                   |

### Character Configurations and Dimensions

|                | Standard    | Double-height | Double-width | Double-width /<br>Double-height |
|----------------|-------------|---------------|--------------|---------------------------------|
|                | W × H (mm)  | W × H (mm)    | W × H (mm)   | W × H (mm)                      |
| Font A 12 × 24 | 1.50 × 3.0  | 1.50 × 6.0    | 3.0 × 3.0    | 3.0 × 6.0                       |
| Font B 9 × 17  | 1.13 × 2.13 | 1.13 × 4.25   | 2.25 × 2.13  | 2.25 × 4.25                     |
| Kanji 24 × 24  | 3.0 × 3.0   | 3.0 × 6.0     | 6.0 × 3.0    | 6.0 × 6.0                       |
| Kanji 20 × 24  | 2.5 × 3.0   | 2.5 × 6.0     | 5.0 × 3.0    | 5.0 × 6.0                       |
| Kanji 16 × 16  | 2.0 × 2.0   | 2.0 × 4.0     | 4.0 × 2.0    | 4.0 × 4.0                       |

The actual print character is smaller than the size shown in the table above, because the above size includes spaces in the font.

Characters can be scaled up to 64 times as large as the standard size.

Character size not including the horizontal spacing in the standard scale is as follows:

Font A (12 × 24): 1.25 (W) × 3.0 mm (H)

Font B (9 × 17): 0.88 (W) × 2.13 mm (H)

## Paper Feed Specifications

| Item                 | Specifications   |
|----------------------|------------------|
| Paper feed method    | Friction feed    |
| Paper feed direction | Single-direction |

### Precautions for Printing and Paper Feed

- Being a line printer, this printer always feeds paper to print. Therefore, when the line spacing of a single line is set to less than that of the print data, paper may be fed more than the setting to print. For example, when the line spacing of a single line is set to 10 dots, paper feed of 10 dots is executed to only make a carriage return, but paper feed of 24 dots is executed to print a bit image. (See the following table.)

#### Paper feed

|                     |            | Necessary paper feed (dots) |
|---------------------|------------|-----------------------------|
| Standard character  | Font A     | 24 × vertical magnification |
|                     | Font B     | 17 × vertical magnification |
|                     | Kanji font | 24 × vertical magnification |
| Rotatable character | Font A     | 12 × vertical magnification |
|                     | Font B     | 9 × vertical magnification  |
|                     | Kanji font | 24 × vertical magnification |
| Bit image           |            | 24 × vertical magnification |

- When the printer is placed in the wait state for data from the host during printing, it temporarily stops printing and paper feed. When data is entered and printing restarts, paper feed may be disturbed between 1 to 3 dot lines at a print start. This especially affects the printing of a bit image.
- It is recommended to start autocutter operation after printing or paper feed of 10 or more lines. (This is because a small piece of cut paper is difficult to eject and may cause a paper jam.)

### Paper Specifications

Refer to "[Consumable Specifications](#)" on page 153.

## Printing Area

### Thermal Paper

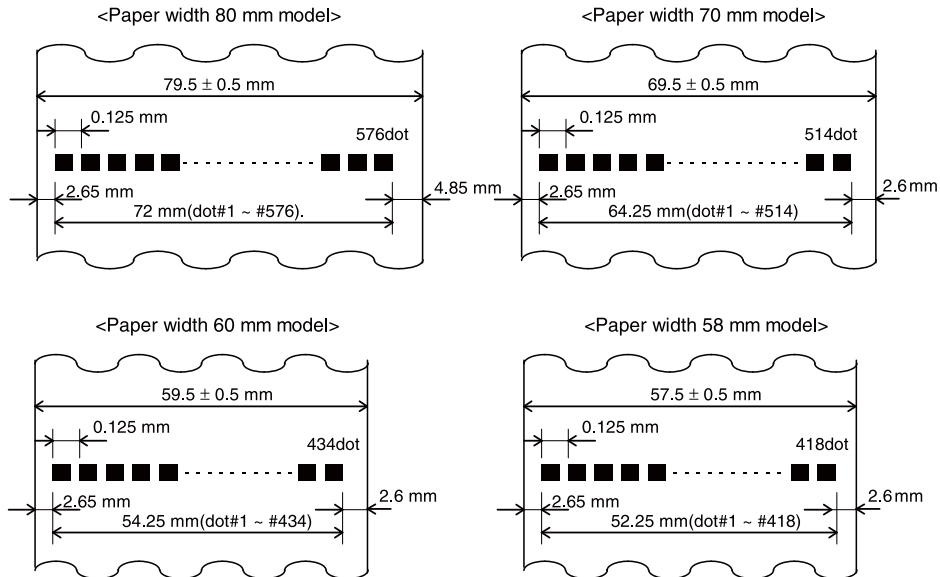

Printable Area (For Thermal Paper)

 **Note:**

The printable area may be out of alignment by 2 mm {0.08"} maximum (left or right), due to the paper position or tolerance of parts. Therefore, the print area must be set in the range of more than 2 mm from the edges of the paper. To make the margin for both sides safely, it is recommended to set a margin of 2.6 mm {0.1"} or more, as shown in figure above.

#### Paper Width and Printable Area

| Paper width (mm)       | (80)  | (70)  | (65)  | (60)  | (58)  | (50)  | (45)  | (38)  |
|------------------------|-------|-------|-------|-------|-------|-------|-------|-------|
| Printable area (mm)    | 72    | 64    | 59    | 54    | 52    | 44    | 39    | 32    |
| Left margin (mm)       | 2.65  | 2.65  | 2.65  | 2.65  | 2.65  | 2.65  | 2.65  | 2.65  |
| Right margin (mm)      | 4.85  | 2.85  | 2.85  | 2.85  | 2.85  | 2.85  | 2.85  | 2.85  |
| Positioning dot number | 1-576 | 1-512 | 1-472 | 1-432 | 1-416 | 1-352 | 1-312 | 1-256 |
| Total number of dots   | 576   | 512   | 472   | 432   | 416   | 352   | 312   | 256   |

Numeric values used above table are center values in designing. Paper width is only for nominal dimension. The values in parentheses are the maximum value for the paper tolerance.

### Die-cut Label

Allow 2.8 mm or more from the left and right edges, and 1.5 mm or more from the top and bottom edges for the printable area.

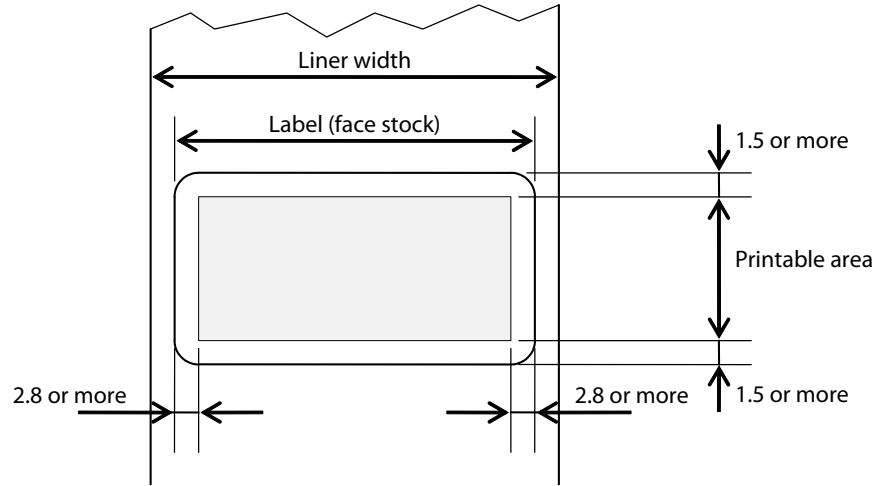

[Units: mm]

Printable Area (for die-cut label)



**Note:**

If the margins are not set, the printing may be off the label due to paper misalignment or the part tolerance.

|                               |        |        |        |        |        |        |
|-------------------------------|--------|--------|--------|--------|--------|--------|
| Liner width (mm)              | (80)   | (70)   | (60)   | (50)   | (45)   | (38)   |
| Label (face stock) width (mm) | 76     | 66     | 56     | 46     | 41     | 34     |
| Printable area (mm)           | 70     | 60     | 50     | 40     | 35     | 28     |
| Left margin (mm)              | 2.9    | 2.9    | 2.9    | 2.9    | 2.9    | 2.9    |
| Right margin (mm)             | 3.1    | 3.1    | 3.1    | 3.1    | 3.1    | 3.1    |
| Positioning dot number        | 17-576 | 17-496 | 17-416 | 17-336 | 17-296 | 17-240 |
| Total number of dots          | 560    | 480    | 400    | 320    | 280    | 224    |

The label must be positioned in the center of the liner. Numeric values used above table are center values in designing. Paper width is only for nominal dimension. The values in parenthesis are the maximum value for the paper tolerance.

### Continuous Label Roll Paper

Allow the left and right margins of 2.8 mm or more outside the printable area.

### Printing Position in Relation to Cutter Position (TM-L90)

The TM-L90 printing position and cutter positions are shown in the following figure.

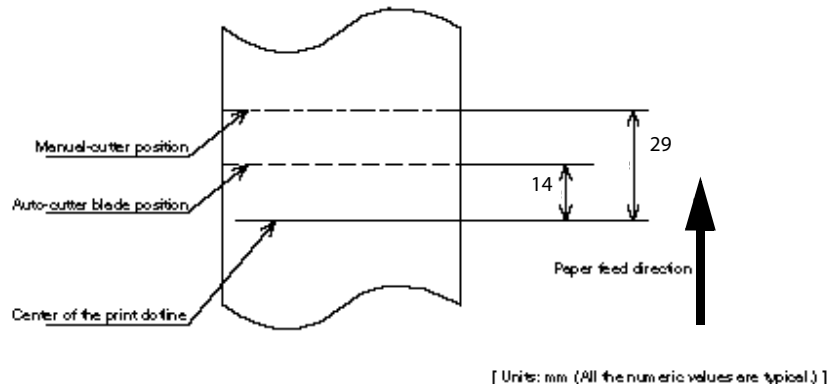

Printing Position in Relation to Cutter Position



**Note:**

The values in the figure are central values. Slackness and differences in paper type can result in differences developing between central values and cutter paper cut position. It is important to allow for a certain margin of error when setting cutter paper cut position.

When operating using the ESC/POS commands, some paper-related commands allow you to feed paper backward after an autocut.

- Back feed maximum amount
- Receipt (without black mark): Approximately 11.5 mm (back feed amount is fixed)
- Receipt (with black mark): Approximately 10.5 mm
- Die-cut label (without black mark): Approximately 10.5 mm
- Die-cut label (with black mark): Approximately 10.5 mm
- Label (no die-cut) (without black mark): Approximately 11.5 mm (back feed amount is fixed)

Do not perform partial cutting and (one point left uncut) reverse feed together.

### **Printing Position, Peeling Position, Manual Cutter Position (TM-L90 Peeler Model)**

The TM-L90 Peeler Model printing position, peeling position and manual cutter positions are shown in the following figure.

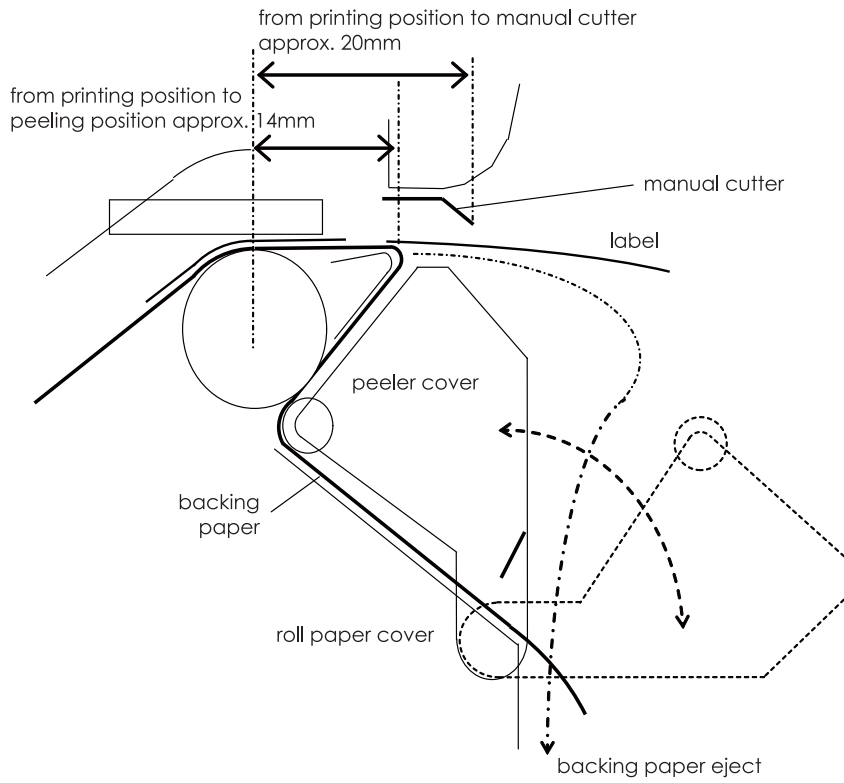

*Printing Position in Relation to Cutter Position*



**Note:**

*The values in the figure above are design center values, and since the paper may be warped or irregular, allow a sufficient margin when setting the cutting position of the manual cutter.*

**Overview of External Dimensions**

- ❑ Height: 203 mm
- ❑ Width: 140 mm
- ❑ Depth: 148 mm
- ❑ Weight: Approximately 1.9 kg (without roll paper)

External view (TM-L90: other than 4\*\* models)

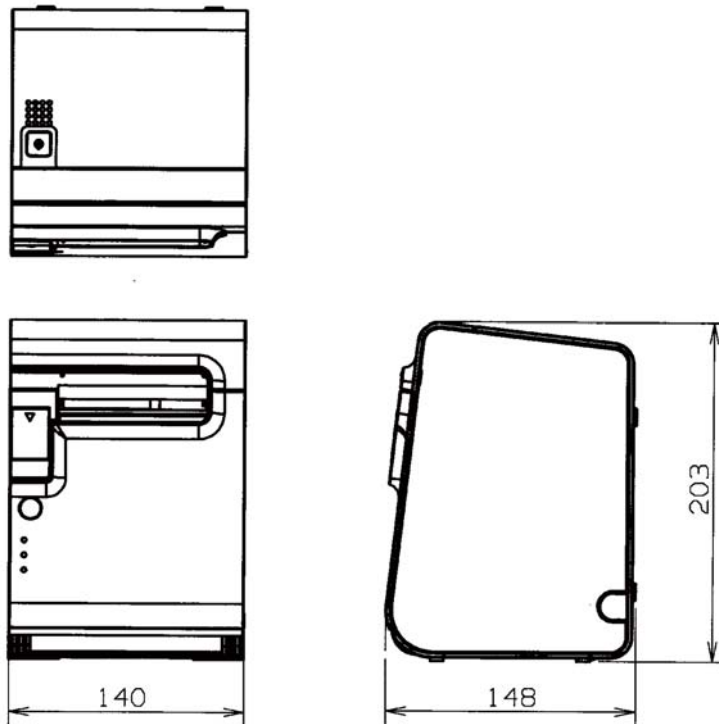

[Units: mm]

*External Appearance (TM-L90)*

External view (TM-L90 Peeler 39\* models)

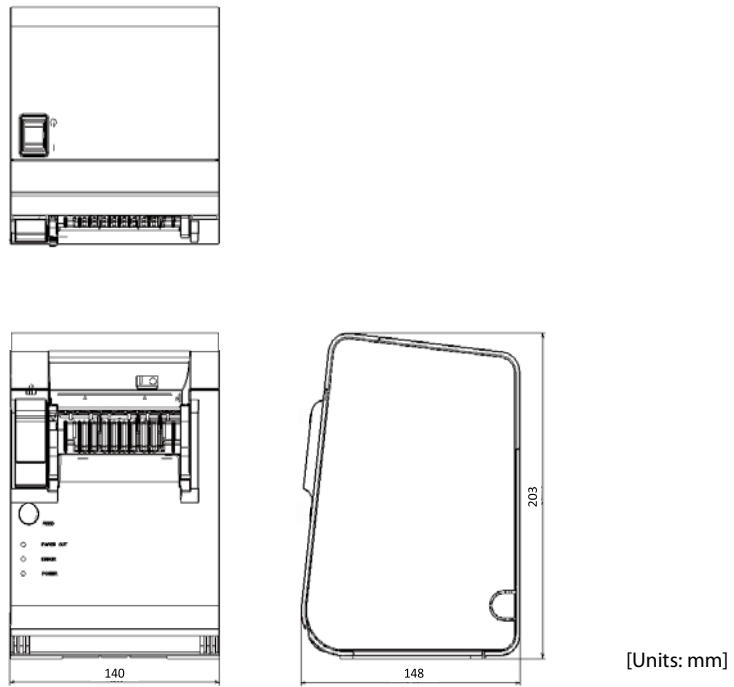

*External Appearance (TM-L90 Peeler Model)*



**Note:**

*As the printer is partly made of coated steel-faced plate, the edges of it may rust. However, it doesn't affect performance of the printer.*

**Operating Specifications**

| Item        |                | Specifications                               |
|-------------|----------------|----------------------------------------------|
| Temperature | When printing  | 5 to 45°C {41 to 113°F}                      |
|             | During storage | -10 to 50°C {14 to 122°F} (except for paper) |
| Humidity    | When printing  | 10 to 90% RH                                 |
|             | During storage | 10 to 90% RH (except for paper)              |

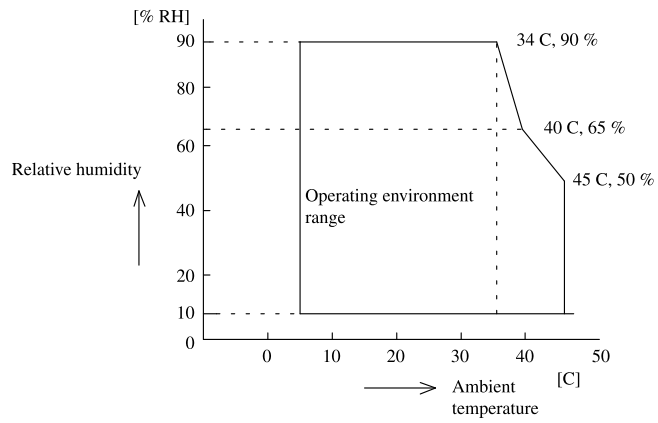

## **Interface And Connectors**

### **RS-232 Serial Interface**

#### **Interface Board Specifications (RS-232 standard)**

| <b>Item</b>          |              | <b>Specifications</b>                                                                                                                                                                                                                                                                                                                                                                                                                                                                                                                                       |
|----------------------|--------------|-------------------------------------------------------------------------------------------------------------------------------------------------------------------------------------------------------------------------------------------------------------------------------------------------------------------------------------------------------------------------------------------------------------------------------------------------------------------------------------------------------------------------------------------------------------|
| Data transfer method |              | Serial                                                                                                                                                                                                                                                                                                                                                                                                                                                                                                                                                      |
| Synchronization      |              | Asynchronous                                                                                                                                                                                                                                                                                                                                                                                                                                                                                                                                                |
| Handshake            |              | Select one of the following using DIP switch 1-3 or the memory switches (switch operation/command (operation)).<br><input type="checkbox"/> DTR/DSR<br><input type="checkbox"/> XON/XOFF                                                                                                                                                                                                                                                                                                                                                                    |
| Signal level         | MARK         | -3 to -15 V logic "1" /Off                                                                                                                                                                                                                                                                                                                                                                                                                                                                                                                                  |
|                      | SPACE        | +3 to +15 V logic "0" /On                                                                                                                                                                                                                                                                                                                                                                                                                                                                                                                                   |
| Bit length           |              | Select one of the following using DIP switch 1-4 or the memory switches (switch operation/command (operation)).<br><input type="checkbox"/> 7 bit<br><input type="checkbox"/> 8 bit                                                                                                                                                                                                                                                                                                                                                                         |
| Baud rate            |              | Select one of the following using DIP switches 1-7/1-8 or the memory switches (switch operation/command (operation)).<br><input type="checkbox"/> 115200 bps (can be set only using the memory switches)<br><input type="checkbox"/> 57600 bps (can be set only using the memory switches)<br><input type="checkbox"/> 38400 bps (can be set only using the memory switches)<br><input type="checkbox"/> 19200 bps<br><input type="checkbox"/> 9600 bps<br><input type="checkbox"/> 4800 bps<br><input type="checkbox"/> 2400 bps<br>[bps: bits per second] |
| Parity check         |              | Select one of the following using DIP switch 1-5 or the memory switches (switch operation/command (operation)).<br><input type="checkbox"/> Yes<br><input type="checkbox"/> No                                                                                                                                                                                                                                                                                                                                                                              |
| Parity selection     |              | Select one of the following using DIP switch 1-6 or the memory switches (switch operation/command (operation)).<br><input type="checkbox"/> Even<br><input type="checkbox"/> Odd                                                                                                                                                                                                                                                                                                                                                                            |
| Stop bit             |              | 1 or more bits<br>However, the stop bit of the transfer data from the printer is fixed at 1 bit.                                                                                                                                                                                                                                                                                                                                                                                                                                                            |
| Connector            | Printer side | Dsub-25pin (female) connector                                                                                                                                                                                                                                                                                                                                                                                                                                                                                                                               |

**Functions of Each Connector Pin**

| Pin no. | Signal name | Signal direction | Function                                                                                                                                                                                                                                                                                                                                                                                                                                                                                                                                                                                                                                                                                        |
|---------|-------------|------------------|-------------------------------------------------------------------------------------------------------------------------------------------------------------------------------------------------------------------------------------------------------------------------------------------------------------------------------------------------------------------------------------------------------------------------------------------------------------------------------------------------------------------------------------------------------------------------------------------------------------------------------------------------------------------------------------------------|
| 1       | FG          | -                | Frame ground                                                                                                                                                                                                                                                                                                                                                                                                                                                                                                                                                                                                                                                                                    |
| 2       | TXD         | Output           | Transfer data                                                                                                                                                                                                                                                                                                                                                                                                                                                                                                                                                                                                                                                                                   |
| 3       | RXD         | Input            | Reception data                                                                                                                                                                                                                                                                                                                                                                                                                                                                                                                                                                                                                                                                                  |
| 4       | RTS         | Output           | Same as DTR signal (Pin 20)                                                                                                                                                                                                                                                                                                                                                                                                                                                                                                                                                                                                                                                                     |
| 6       | DSR         | Input            | This signal indicates whether the host computer can receive data. SPACE indicates that the host computer can receive data, and MARK indicates that the host computer cannot receive data.<br>When DTR/DSR control is selected, the printer transmits data after confirming this signal.(Except as transmitted using some ESC/POS commands)<br>When XON/XOFF control is selected, the printer does not check this signal.<br>Changing the memory switch 1-7 setting enables this signal to be used as a reset signal for the printer.<br>The printer is reset when the signal remains MARK for 1 ms or more.                                                                                     |
| 7       | SG          | -                | Signal ground                                                                                                                                                                                                                                                                                                                                                                                                                                                                                                                                                                                                                                                                                   |
| 20      | DTR         | Output           | 1) When DTR/DSR control is selected, this signal indicates whether the printer is busy. SPACE indicates that the printer is ready to receive data, and MARK indicates that the printer is busy. The busy condition can be changed by using memory switch 1-3. (Refer to "Busy state" on page 91)<br>2) When XON/XOFF control is selected:<br>The signal indicates whether the printer is correctly connected and is ready to receive data. SPACE indicates that the printer is ready to receive data. The signal is always SPACE except in the following cases:<br>• During the period from when the power is turned on to when the printer is ready to receive data.<br>• During the self test |
| 25      | INIT        | Input            | Changing the memory switch 1-8 setting enables this signal to be used as a reset signal for the printer.<br>The printer is reset when the signal remains SPACE for 1 ms or more.*                                                                                                                                                                                                                                                                                                                                                                                                                                                                                                               |

\*: Available only for TM-L90 other than 4\*\* models, TM-L90 Peeler other than 39\* models

## XON/XOFF

When XON/XOFF control is selected, the printer transmits XON or XOFF signals as follows. Transmit timing differs depending on the memory switch 1-3 setting.

| Signal | Printer status                                                                        | Memory Switch 1-3 |          |
|--------|---------------------------------------------------------------------------------------|-------------------|----------|
|        |                                                                                       | 1(ON)             | 0(OFF)   |
| XON    | 1) When the printer goes online after turning on the power (or reset using interface) | Transmit          | Transmit |
|        | 2) When the receive buffer is released from the buffer full state                     | Transmit          | Transmit |
|        | 3) When the printer switches from offline to online                                   | -                 | Transmit |
|        | 4) When the printer recovers from an error using some ESC/POS commands.               | -                 | Transmit |
| XOFF   | 5) When the receive buffer becomes full                                               | Transmit          | Transmit |
|        | 6) When the printer switches from online to offline                                   | -                 | Transmit |

## Code

The XON/XOFF codes are shown below.

- XON code: <11>H
- XOFF code: <13>H



### Note:

*When the printer goes from offline to online mode and the receive buffer is full, XON is not transferred.*

*When the printer goes from online to offline mode and the receive buffer is full, XOFF is not transferred.*

*When memory switch Msw 1-3 is off, XON is not transferred as long as the printer is offline even if a receive buffer full state has been cleared.*

## IEEE1284 Parallel Interface

### Mode

The IEEE1284 parallel interface is comprised of the following two modes.

| Mode               | Communication direction      | Other information                                     |
|--------------------|------------------------------|-------------------------------------------------------|
| Compatibility Mode | Host → printer communication | Centronics standard                                   |
| Reverse Mode       | Printer → host communication | Assumes a data transfer from an asynchronous printer. |

#### ☐ Compatibility Mode

Compatibility Mode is Data Transmission from Host to Printer: Centronics compatible.

#### Specifications

- Data transmission: 8-bit Parallel
- Synchronization: Externally supplied n\*Strobe signals
- Handshaking: n\*Ack and Busy signals
- Signal levels: TTL compatible
- Connector: ADS-B36BLFDR176 (HONDA) or equivalent (IEEE 1284 Type B)
- Reverse communication (Printer Host): Nibble or Byte Mode

\* n before the signal name indicates active LOW.

#### ☐ Reverse Mode

The status data transmission from the printer to the host proceeds in the Nibble or Byte mode.

This mode allows data transmission from the asynchronous printer under the control of the host. Data transmissions in the Nibble Mode are made via the existing control lines in units of four bits (Nibble). In the Byte Mode, data transmissions proceed by making the eight-bits data lines bidirectional. Both modes fail to proceed concurrently with the Compatibility Mode, thereby causing half duplex transmission.

## Interface Signals

### Connector Pin Assignment

| Pin | Source   | Compatibility Mode | Nibble Mode        | Byte Mode   |
|-----|----------|--------------------|--------------------|-------------|
| 1   | Host     | nStrobe            | HostClk            | HostClk     |
| 2   | Host/Ptr | Data0(LSB)         | Data0(LSB)         | Data0(LSB)  |
| 3   | Host/Ptr | Data1              | Data1              | Data1       |
| 4   | Host/Ptr | Data2              | Data2              | Data2       |
| 5   | Host/Ptr | Data3              | Data3              | Data3       |
| 6   | Host/Ptr | Data4              | Data4              | Data4       |
| 7   | Host/Ptr | Data5              | Data5              | Data5       |
| 8   | Host/Ptr | Data6              | Data6              | Data6       |
| 9   | Host/Ptr | Data7(MSB)         | Data7(MSB)         | Data7(MSB)  |
| 10  | Printer  | nAck               | PtrClk             | PtrClk      |
| 11  | Printer  | Busy               | PtrBusy/Data3,7    | PtrBusy     |
| 12  | Printer  | Perror             | AckDataReq/Data2,6 | AckDataReq  |
| 13  | Printer  | Select             | Xflag/Data1,5      | Xflag       |
| 14  | Host     | nAutoFd            | HostBusy           | HostBusy    |
| 15  |          | NC                 | ND                 | ND          |
| 16  |          | GND                | GND                | GND         |
| 17  |          | FG                 | FG                 | FG          |
| 18  | Printer  | Logic-H            | Logic-H            | Logic-H     |
| 19  |          | GND                | GND                | GND         |
| 20  |          | GND                | GND                | GND         |
| 21  |          | GND                | GND                | GND         |
| 22  |          | GND                | GND                | GND         |
| 23  |          | GND                | GND                | GND         |
| 24  |          | GND                | GND                | GND         |
| 25  |          | GND                | GND                | GND         |
| 26  |          | GND                | GND                | GND         |
| 27  |          | GND                | GND                | GND         |
| 28  |          | GND                | GND                | GND         |
| 29  |          | GND                | GND                | GND         |
| 30  |          | GND                | GND                | GND         |
| 31  | Host     | nInit              | nInit              | nInit       |
| 32  | Printer  | nFault             | nDataAvail/Data0,4 | nDataAvail  |
| 33  |          | GND                | ND                 | ND          |
| 34  | Printer  | DK_STATUS          | ND                 | ND          |
| 35  | Printer  | +5 V               | ND                 | ND          |
| 36  | Host     | nSelectIn          | 1284-Active        | 1284-Active |

\*NC: None Connect

ND: Not Defined



**Note:**

*A signal name prefixed by "n" indicates an "L" active signal.*

*Bidirectional communications cannot take place unless all signal names for both sides correspond to each other.*

*Connect all signal lines using twisted pair cables. Connect the return side to the signal ground level.*

*Make sure that the signals satisfy electrical characteristics.*

*Set the leading edge and trailing edge times to 0.5  $\mu$ s or less.*

*Do not ignore nAck or BUSY signals during a data transfer. Ignoring such signals may result in data corruption.*

*Make the interface cables as short as possible.*

## USB Interface

### USB interface connector

USB type-B connector

### USB transmission specifications

#### USB function

|                                                 |                                                                                                                          |          |
|-------------------------------------------------|--------------------------------------------------------------------------------------------------------------------------|----------|
| Overall specifications                          | According to USB 2.0 specifications                                                                                      |          |
| Transmission speed                              | USB Full-Speed (12 Mbps)                                                                                                 |          |
| Transmission method                             | USB bulk transmission method                                                                                             |          |
| Power supply specifications                     | USB self power supply function                                                                                           |          |
| Current consumed by USB bus                     | 2 mA                                                                                                                     |          |
| USB packet size<br>(with full-speed connection) | USB bulk OUT (TM)                                                                                                        | 64 bytes |
|                                                 | USB bulk IN (TM)                                                                                                         | 64 bytes |
| USB device class                                | Both USB vendor-defined class and USB printer class are supported.<br>The class switches when software setting startups. |          |



#### Note:

To set the USB device class, see ["Memory Switch Settings" on page 42](#).

#### USB descriptor

|                   |               | USB vendor-defined class                            | USB printer class                                   |
|-------------------|---------------|-----------------------------------------------------|-----------------------------------------------------|
| Vendor ID         |               | 04B8h                                               | 04B8h                                               |
| Product ID        |               | 0202h                                               | 0E16h                                               |
| String Descriptor | Manufacturer  | EPSON                                               | EPSON                                               |
|                   | Product       | TM-L90                                              | TM-L90                                              |
|                   | Serial number | Character string based on the product serial number | Character string based on the product serial number |

#### Status transmission from printer with USB interface

In order to ensure that there is no lack of status data, it is necessary to periodically retrieve status data at the host computer.

Unlike RS-232 transmission, it cannot spontaneously interrupt data transmission to the host computer.

The printer has a 128-byte status data buffer. Statuses that exceed the buffer capacity are cancelled.

## Option Specifications

This appendix describes the optional power supply (PS-180/PS-190).

### PS-180

#### Electrical Characteristics

❑ Input conditions

|                         |                                                  |
|-------------------------|--------------------------------------------------|
| Input voltage (rating): | AC 90 to 264 V<br>(AC 100 V-10% to AC 230 V+15%) |
| Frequency (rating):     | 50/60±3 Hz                                       |
| AC switch               | ---                                              |
| LED                     | ---                                              |

❑ Output conditions

|                                 |            |
|---------------------------------|------------|
| Output voltage (rating):        | DC 24 V±5% |
| Output current (rating):        | 2.1 A      |
| Output electric power (rating): | 50.6 VA    |
| Output peak current:            | 4.5 A      |

#### Case Specifications

- ❑ Size: 68 × 136 × 32 mm (D × L × H, excluding projections)  
Refer to figure below.
- ❑ Weight: Approx. 0.4 kg (excluding the AC cable)
- ❑ Material: Flame-resistance grade: V0
- ❑ Color: Black (matte)

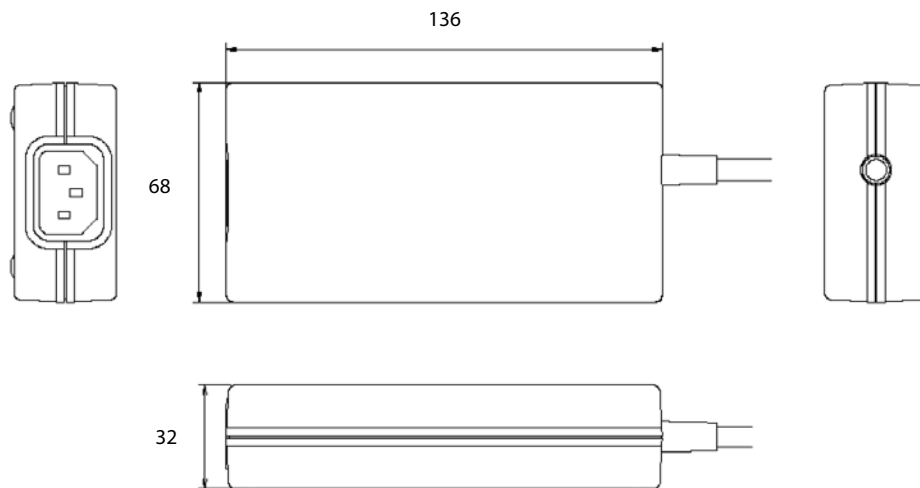

Case specifications

## PS-190

### Electrical Characteristics

Input conditions

|                         |                                                  |
|-------------------------|--------------------------------------------------|
| Input voltage (rating): | AC 90 to 264 V<br>(AC 100 V-10% to AC 230 V+15%) |
| Frequency (rating):     | 50/60±3 Hz                                       |
| AC switch               | ---                                              |
| LED                     | ---                                              |

Output conditions

|                                 |            |
|---------------------------------|------------|
| Output voltage (rating):        | DC 24 V±5% |
| Output current (rating):        | 2.1 A      |
| Output electric power (rating): | 50.4 VA    |
| Output peak current:            | 4.5 A      |

### Case Specifications

- Size: 56 × 114 × 32 mm (D × L × H, excluding projections)  
Refer to figure below.
- Weight: Approx. 0.3 kg (excluding the AC cable)
- Material: Flame-resistance grade: V0
- Color: Black (matte)

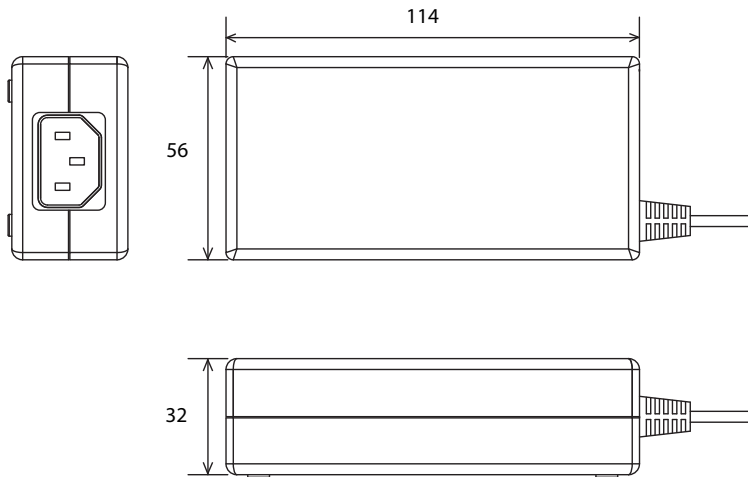

Case specifications

### Material

No specific brominated flame retardants such as PBBE, PBB are used in this product.

### AC Cable Selection

- Select an AC cable that satisfies the following conditions.
  - Safety Standard product
  - Plug with P.E terminal
- Ground connection: Ground certainly for safety.

## Consumable Specifications

### Paper Specification

|                               |                     |                                                                                                                                                                                                                                                                                                                                                                                                                                                                                                                                                                                                                                                                                                                                                                           |
|-------------------------------|---------------------|---------------------------------------------------------------------------------------------------------------------------------------------------------------------------------------------------------------------------------------------------------------------------------------------------------------------------------------------------------------------------------------------------------------------------------------------------------------------------------------------------------------------------------------------------------------------------------------------------------------------------------------------------------------------------------------------------------------------------------------------------------------------------|
| Paper type                    |                     | <p>Thermal paper</p> <ul style="list-style-type: none"> <li>• Receipt paper (without black marks)</li> <li>• Receipt paper (with black marks)</li> <li>• Continuous label paper (without black marks) *</li> <li>• Continuous label paper (with black marks) *</li> <li>• Die-cut label paper (without black marks)</li> <li>• Die-cut label paper (with black marks)</li> </ul> <p>* Continuous label paper may not be used with TM-L90 Peeler Model.</p>                                                                                                                                                                                                                                                                                                                |
| Form                          |                     | Roll paper                                                                                                                                                                                                                                                                                                                                                                                                                                                                                                                                                                                                                                                                                                                                                                |
| Size                          | Paper width         | <ul style="list-style-type: none"> <li>• 79.5±0.5 mm {3.13±0.02"}</li> <li>• 37.5±0.5 to 59.5±0.5 mm {1.48±0.02 to 2.34±0.02"}</li> </ul>                                                                                                                                                                                                                                                                                                                                                                                                                                                                                                                                                                                                                                 |
|                               | Paper thickness     | 145 mm or less                                                                                                                                                                                                                                                                                                                                                                                                                                                                                                                                                                                                                                                                                                                                                            |
|                               | Roll paper width    | <ul style="list-style-type: none"> <li>• 80+0.5/-1.0 mm {3.15+0.02/-0.04"}</li> <li>• 38 to 70+0.5/-1.0 mm {1.5 to 2.76+0.02/-0.04"}</li> </ul>                                                                                                                                                                                                                                                                                                                                                                                                                                                                                                                                                                                                                           |
|                               | Roll paper core     | <p>Receipt paper</p> <p>inside: 12 mm {0.47"} or more</p> <p>outside: 18 mm {0.71"} or more</p> <p>Label paper</p> <p>inside: 25.4 mm {1.00"} or more</p> <p>outside: 31.4 mm {1.24"} or more</p> <p>* Continuous label paper may not be used with TM-L90 Peeler Model.</p>                                                                                                                                                                                                                                                                                                                                                                                                                                                                                               |
|                               | Roll paper diameter | 90 mm {3.54"} maximum                                                                                                                                                                                                                                                                                                                                                                                                                                                                                                                                                                                                                                                                                                                                                     |
| Specified roll paper type     |                     | <p>Receipt roll paper:<br/>see <a href="#">"Specified receipt roll paper" on page 155</a></p> <p>Die-cut label roll paper:<br/>see <a href="#">"Specified die-cut label roll paper" on page 155</a></p> <p>Continuous label roll paper:<br/>see <a href="#">"Specified continuous label roll paper" on page 155</a></p>                                                                                                                                                                                                                                                                                                                                                                                                                                                   |
| Specified original paper type |                     | <p>TM-L90:</p> <p>Thermal paper:</p> <p>P35024 (Kanzaki Specialty Paper (USA))</p> <p>F5041(55) (Mitsubishi HiTec Paper Europe GmbH)</p> <p>KF50 (KANZAN Spezialpapiere GmbH)</p> <p>Label paper:</p> <p>DTM9502 (Label face stock:KL370 or KIP37032) (MACTac)<br/>(Face stock is Kanzaki Specialty Paper (USA))</p> <p>KL80GT (Nakagawa Mfg. Deutschland GmbH)<br/>(Face stock is KANZAN Spezialpapiere GmbH)</p> <p>150PSMW (Ricoh Company, Ltd..)</p> <p>TM-L90 Peeler Model:</p> <p>Thermal paper:</p> <p>P35024 (Kanzaki Specialty Paper (USA))</p> <p>F5041(55) (Mitsubishi HiTec Paper Europe GmbH)</p> <p>KF50 (KANZAN Spezialpapiere GmbH)</p> <p>Label paper:</p> <p>KL80GT (Nakagawa Mfg. Deutschland GmbH)<br/>(Face stock is KANZAN Spezialpapiere GmbH)</p> |



**NOTE:**

- ❑ Paper must not be pasted to the roll paper core.
- ❑ Using roll paper with an inside diameter of 25.4 mm {1"} or less may decrease the detection accuracy of the roll paper near-end sensor.
- ❑ Use of thermal paper with a pre-printed recording surface should be avoided. Using it can cause the thermal head to stick to the thermal paper surface during printing, and cause printing failure and other problems. The pre-printing also can result in reduced print density. Using thermal paper with a pre-printed recording surface, pre-printing should be done in accordance with the conditions (ink type, printing and other conditions) recommended by the paper manufacturer, and the thermal paper should be checked to ensure that there is no faulty printing, loss of print density, or other problems.

## Specified Roll Paper

### Specified receipt roll paper

| Roll paper type no. | Printing method | Paper width   | Length                  | Rolls/box | Other                                                  |
|---------------------|-----------------|---------------|-------------------------|-----------|--------------------------------------------------------|
| NTP080-80           | Thermal         | 80 mm {3.15"} | Approx. 78 m {3070.87"} | 3 rolls   | --                                                     |
| NTP060-80           | Thermal         | 60 mm {2.36"} | Approx. 78 m {3070.87"} | 3 rolls   | Warranty period: 5 years with 20 degrees, humidity 60% |
| NTP080-ATG          | Thermal         | 80 mm {3.15"} | Approx. 39 m {1535.43"} | 3 rolls   | Paper thickness: 0.145 mm {0.0057"}                    |

### Specified die-cut label roll paper

| Roll paper type no. | Printing method | Paper width   | Length                 | Rolls/box | Other                                                                          |
|---------------------|-----------------|---------------|------------------------|-----------|--------------------------------------------------------------------------------|
| NTL080-901          | Thermal label   | 80 mm {3.15"} | Approx. 40 m {1574.8"} | 3 rolls   | Number of labels: Approx. 1310 labels/roll<br>Label size: 76 (W) × 25.4 mm (H) |
| NTL080-902          | Thermal label   | 80 mm {3.15"} | Approx. 40 m {1574.8"} | 3 rolls   | Number of labels: Approx. 710 labels/roll<br>Label size: 76 (W) × 50.8 mm (H)  |
| NTL080-903          | Thermal label   | 80 mm {3.15"} | Approx. 40 m {1574.8"} | 3 rolls   | Number of labels: Approx. 490 labels/roll<br>Label size: 76 (W) × 76.2 mm (H)  |
| NTL080-904          | Thermal label   | 80 mm {3.15"} | Approx. 40 m {1574.8"} | 3 rolls   | Number of labels: Approx. 370 labels/roll<br>Label size: 76 (W) × 101.6 mm (H) |
| NTL060-901          | Thermal label   | 60 mm {2.36"} | Approx. 40 m {1574.8"} | 3 rolls   | Number of labels: Approx. 1310 labels/roll<br>Label size: 56 (W) × 25.4 mm (H) |
| NTL060-902          | Thermal label   | 60 mm {2.36"} | Approx. 40 m {1574.8"} | 3 rolls   | Number of labels: Approx. 710 labels/roll<br>Label size: 56 (W) × 50.8 mm (H)  |
| NTL060-903          | Thermal label   | 60 mm {2.36"} | Approx. 40 m {1574.8"} | 3 rolls   | Number of labels: Approx. 490 labels/roll<br>Label size: 56 (W) × 76.2 mm (H)  |
| NTL060-904          | Thermal label   | 60 mm {2.36"} | Approx. 40 m {1574.8"} | 3 rolls   | Number of labels: Approx. 370 labels/roll<br>Label size: 56 (W) × 101.6 mm (H) |
| NTL038-901          | Thermal label   | 38 mm {1.50"} | Approx. 40 m {1574.8"} | 3 rolls   | Number of labels: Approx. 1310 labels/roll<br>Label size: 34 (W) × 25.4 mm (H) |

### Specified continuous label roll paper

| Roll paper type no. | Printing method | Paper width   | Length                 | Rolls/box | Other                                            |
|---------------------|-----------------|---------------|------------------------|-----------|--------------------------------------------------|
| NTL080-ZEN          | Thermal label   | 80 mm {3.15"} | Approx. 40 m {1574.8"} | 3 rolls   | Continuous label, label size 76 mm {2.99"} width |

## Requirements for Receipt Paper

### Black mark position for receipt paper

When manufacturing receipt paper with black marks, be sure to make paper that meets the following requirements.

The reflecting rates of black mark portions (1) and non black mark portions (2) must meet the combinations shown in the table below:

- ❑ Black mark length in vertical: 4 to 7.5 mm {0.157 to 0.295"}
- ❑ Black mark position: Any places

|                                                                        |     |     |     |     |     |      |
|------------------------------------------------------------------------|-----|-----|-----|-----|-----|------|
| Reflecting rate of black mark portion (1)                              | 17% | 16% | 15% | 14% | 13% | Less |
| Reflecting rate of the portion where the black mark does not exist (2) | 90% | 85% | 80% | 75% | 70% | More |

NOTE: Reflecting rates are measured by the Macbeth PCM-II (Filter D) meter.

Paper without intervals between labels, such as continuous label paper, paper with perforated lines between labels, and paper with slits between labels, can also be used under the same requirements.

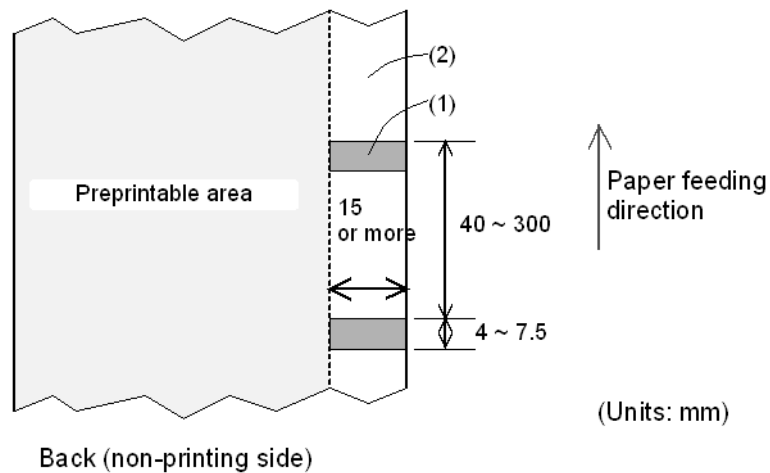

*Black Mark Interval Requirement*

### **Requirements for Die-Cut Label Paper**

Die-cut label paper is shown below.



Example of transparency label roll paper

Features:

- Paper layout can be set automatically ("[Paper Loading Method](#)" on page 53)
- Paper layout can be set manually ("[Paper Loading Method](#)" on page 53)
- Transparency label roll paper or label roll paper with black marks can be used.

### Die-cut label size

When manufacturing die-cut label paper, be sure that the paper meets the following requirements.

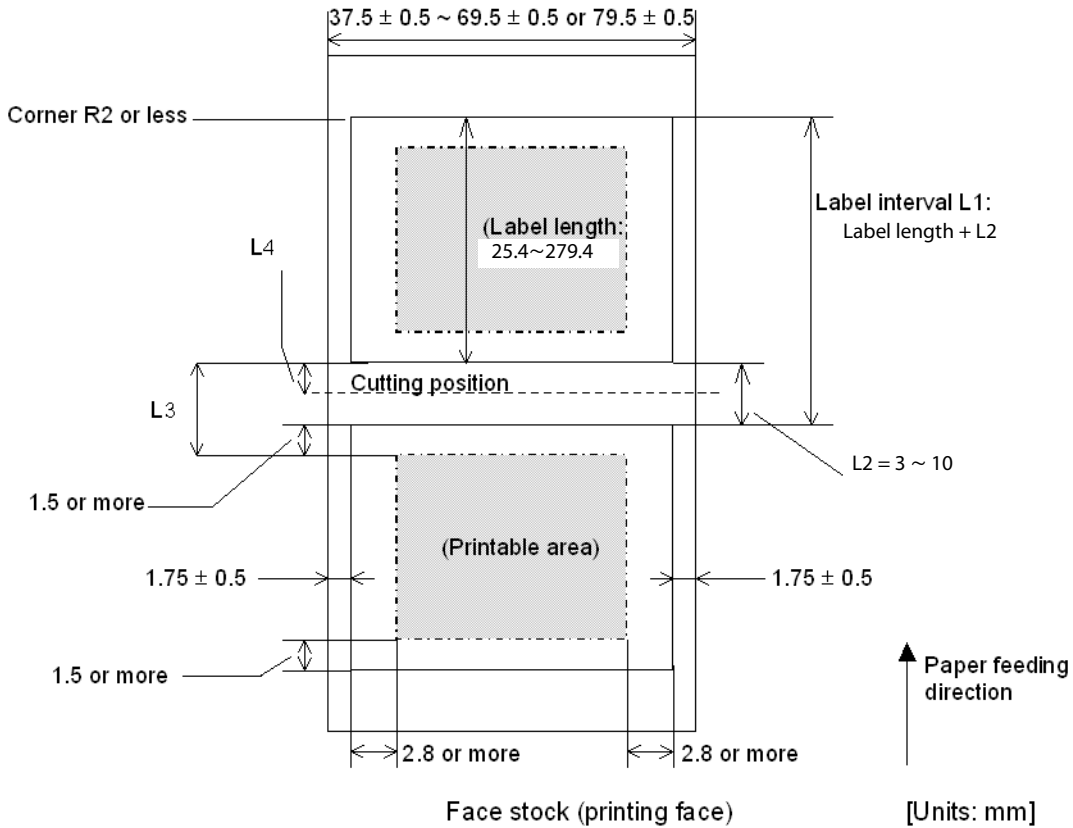

Label Size Requirement



#### Note:

- ❑ Be sure to set the cutting position (L4) between labels.
- ❑ Be sure that the distance from the cutting position to the print starting position (=L3-L4) is 2.75 mm {0.11"} or more.

### Black mark position for die-cut label paper

If die-cut label with black marks is used, there are two reflective rate requirements, depending on the size and position of black marks. Be sure to use label paper that meets either black mark position requirement I or II as follows:

**Black mark position I**

The black mark positions on the paper to be manufactured must meet the requirements in the figure below. The reflective rates of the black mark portions 1 and label portions 2 must meet the combinations shown in the table below (the reflective rate is measured using the back of the paper, the non-printing side):

|                                          |     |     |     |     |     |      |
|------------------------------------------|-----|-----|-----|-----|-----|------|
| Reflecting rate for black mark portion 1 | 17% | 16% | 15% | 14% | 13% | Less |
| Reflecting rate for label portion 2      | 90% | 85% | 80% | 75% | 70% | More |

NOTE: Reflective rates are measured by the Macbeth PCM-II (Filter D) meter.

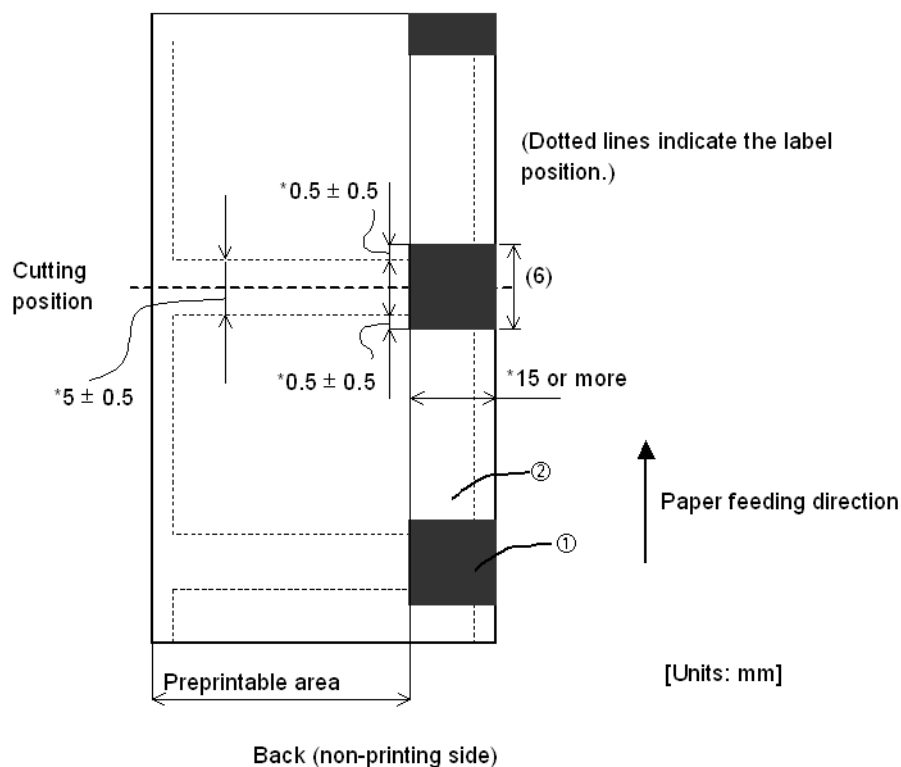

NOTE: Dimensions marked with \* must be kept.

**Black mark position II**

The black mark positions on the paper to be manufactured must meet the requirements in the figure below (the reflective rate is measured using the back of the paper, the non-printing side):

- ❑ Black mark length in vertical: 4 to 5.5 mm {0.157 to 0.217"}
- ❑ Black mark position: Any places

|                                                                        |     |     |     |     |     |      |
|------------------------------------------------------------------------|-----|-----|-----|-----|-----|------|
| Reflecting rate of black mark portion (1)                              | 17% | 16% | 15% | 14% | 13% | Less |
| Reflecting rate of the portion where the black mark does not exist (2) | 90% | 85% | 80% | 75% | 70% | More |

NOTE: Reflective rates are measured by the Macbeth PCM-II (Filter D) meter.

If label paper meets Black Mark Position Requirement I, it is not necessary to consider Black Mark Position Requirement II.

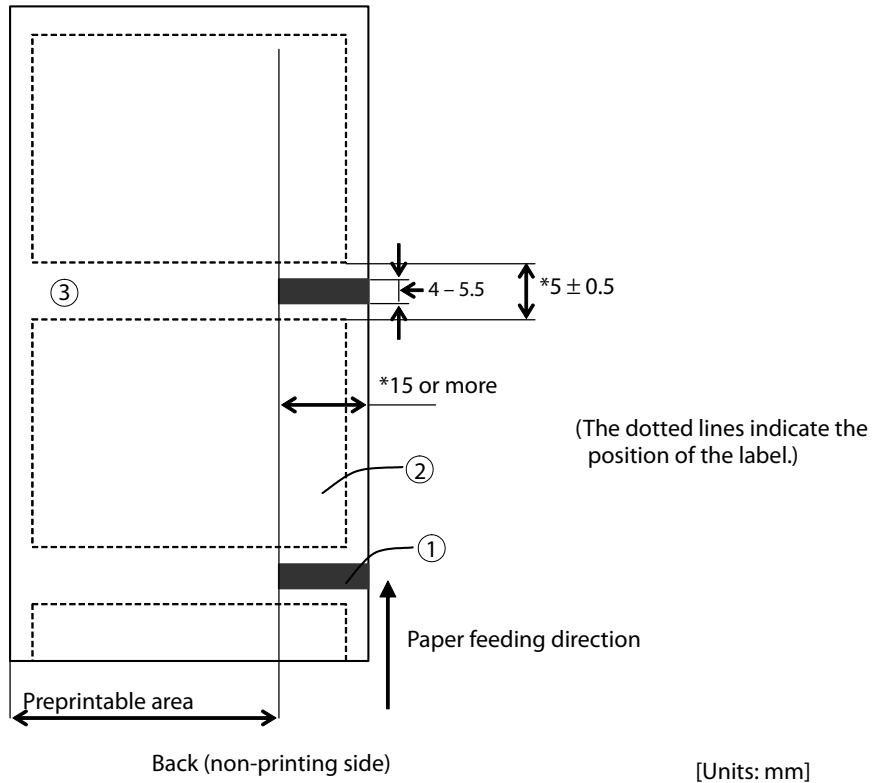

NOTE: Dimensions marked with \* must be kept.

**Transparency rate of die-cut label paper**

If transparency (without black marks) label is used, use a label that meets the following requirements so that the printer can recognize the label position:

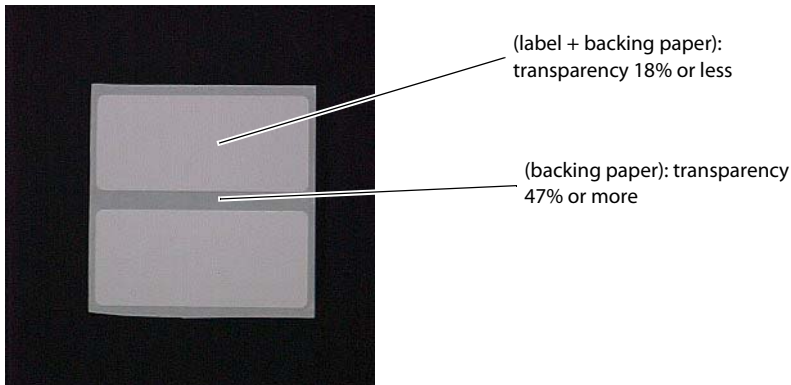

 **Note:**

- Transparency rates are measured by the Macbeth TD-904 (with a filter for infrared) photometer. The transparency rates are calculated as follows:

Use

$$\text{Density} = \text{Log}^{10} (\text{Amount of irradiation} / \text{Amount of transparency})$$

Then,

$$\text{Transparency rate (\%)} = (\text{Amount of transparency} / \text{Amount of irradiation}) \times 100$$

- If the transparency rates are out of the specified range (label + backing paper: 18% or less, backing paper: 47% or more), the printer detects a layout error. However, paper identified with a layout error may be used when the detection hole is prepared as follows. The position to detect the label may be shifted by approximately 0.5 mm {0.02"}.

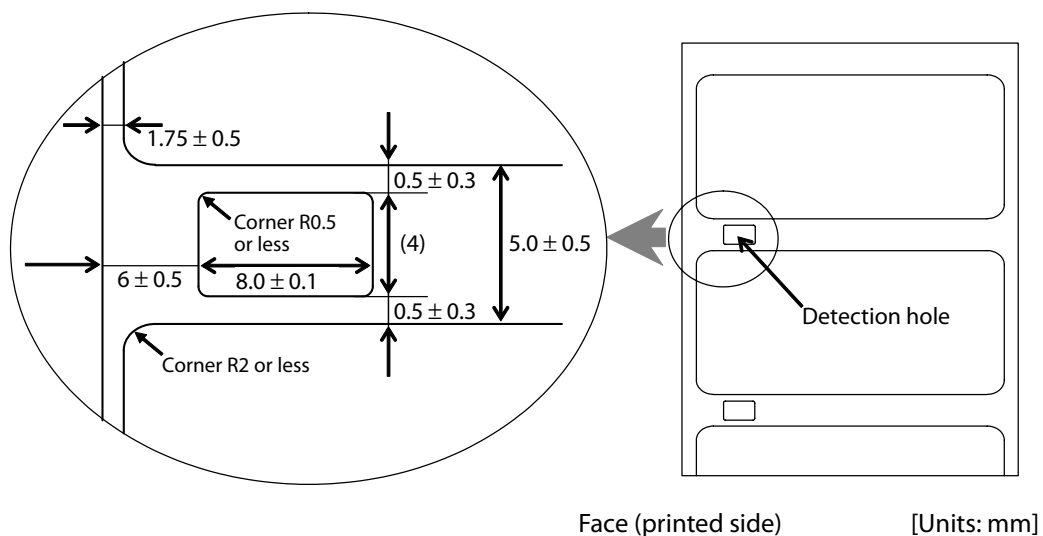

## Other requirements

Requirements for the thickness of the die-cut label paper, peeling strength against backing paper, and the adhesive agent that can be used with the printer are shown in the figure below:

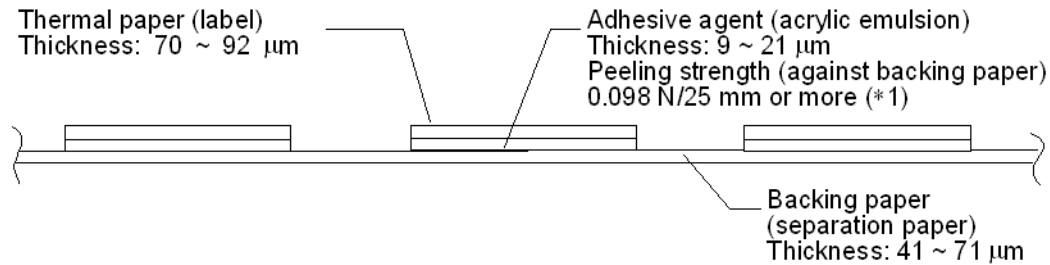

*Die-Cut Label Paper Thickness, Peeling Strength, and Adhesive Agent*

Peeling strength of the label against backing paper, measured by FINAT FTM-1 (Europe), ASTM D3330/D3330M-02 (U.S.A.).



### Note:

- ❑ Total of thermal paper and backing paper: 145 μm or less (excluding adhesive agent)
- ❑ Adhesive agent: acrylic emulsion

## Requirements for Continuous Label Paper

Continuous label paper is label roll paper without labels die-cut in predefined sizes. There are types, back slit type or cut-off edge type:

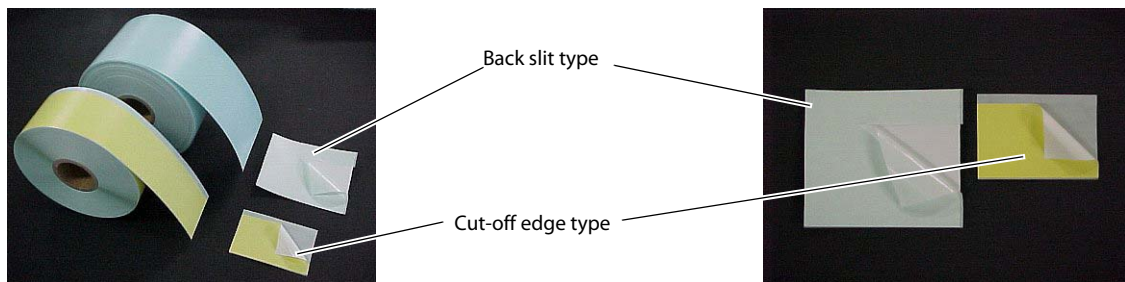

Feature: Label size (length) is variable with an autocutter; therefore, it is possible to print labels of various sizes. Compared with die-cut label, it is economic because of no die-cut cut-off edges.



### Note:

*Cut-off edges make it easier to remove a label from backing paper.*

**Size of continuous label paper**

To prevent the print head from sticking to the adhesive agent, be sure to use continuous label paper that has a cut-off edge.



*Note:* “cut-off edge” is a method of cutting and removing the edge of the label in advance so that the label can be peeled off easily from the backing paper.

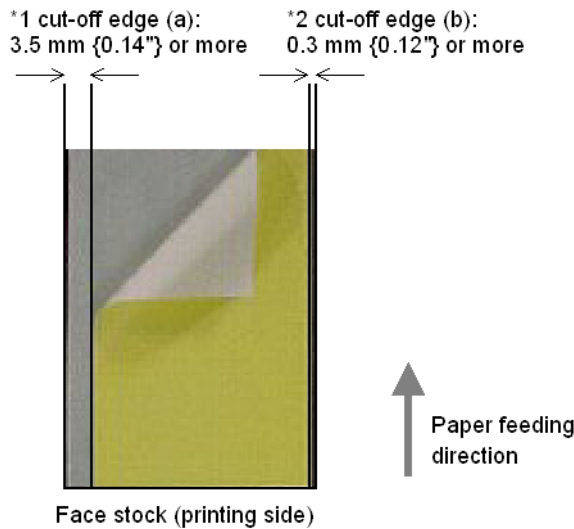

Requirements for Size of Label Paper of the Cut-Off Edge Type



*Note:* When using a label with 80 mm {3.15"} paper width, the cut-off edge (b) is not necessary; however, it is recommended that cut-off edges with approximately 2 mm {0.79"} width be provided for both edges so that the label can be peeled off easily from the backing paper.

**Black mark position for continuous label paper**

Refer to "Black mark position for receipt paper" on page 156.

## **Notes on Paper Handling**

### **Thermal paper handling**

Substances such as chemicals on thermal paper may cause color development or faded printing; therefore, pay attention to the following:

- ❑ Use water paste, starch paste, polyvinyl paste, or CMC paste when gluing thermal paper.
- ❑ Volatile organic solvents such as alcohol, ester, and ketone can cause discoloration.
- ❑ Some discoloration may occur, depending on adhesive materials. Printing may be faded, depending on materials of tapes.
- ❑ If thermal paper touches anything that includes phthalic acid ester plasticizer for a long time, it can reduce the image-formation ability of the paper and can cause the printed image to fade. Therefore, when storing thermal paper in a card case or sample notebook, be sure to use only products made from polyethylene, polypropylene, or polyester.
- ❑ If thermal paper touches diazo copy paper immediately after copying, the printed surface may be discolored.
- ❑ Thermal paper must not be stored with the printed surfaces against each other because the printing may be transferred between surfaces.
- ❑ If the surface of thermal paper is scratched with a nail or hard metal object, the paper may become discolored.

### **Notes on storage**

Since discoloration begins at 70°C {158°F}, thermal paper should be protected from high temperatures, humidity, and light, both before and after printing.

- ❑ Store paper away from high temperatures and humidity.  
Do not store thermal paper near a heater or in enclosed places exposed to direct sunlight.
- ❑ Avoid direct light.
- ❑ Extended exposure to direct light (as with placement of the printer near windows) may cause discoloration or faded printing.
- ❑ When the printer is not used for one week or more, it is recommended not to leave the thermal paper between the platen and the print head.

---

## **Character Code Table**

See the Character Code Tables for TM Printers that can be accessed from the following URL:

[https://support.epson.net/publist/reference\\_en/](https://support.epson.net/publist/reference_en/)